

# LINEEYE

*MULTI PROTOCOL ANALYZER*

***LE-8500XR***

***LE-8500X***

---

---

## INSTRUCTION MANUAL

---

---



# Instruction

---

---

Thank you for your purchase of LE series.

To use it correctly, you are advised to read and understand this instruction manual thoroughly. Keep this together with the warranty. If you encounter any problems, you will find helpful information in this manual.



## NOTICE

---

It is prohibited to reprint or duplicate any part of the whole of this instruction manual without prior permission from LINEEYE.

The content of this instruction manual and specifications of the products are subject to change without any notice.

This instruction manual has been designed and edited with great care to give you all necessary information. If you have any questions, feel free to direct your inquiries to LINEEYE.

LINEEYE makes no warranty or guarantee, either expressed or implied with respect to its quality, performance, merchantability, or fitness for a particular purpose. LINEEYE shall not be liable for direct, indirect, special, incidental, or consequential damages resulting from any defect in the product. The warranty and remedies set forth above are exclusive and in lieu of all others.



## USER LIMITATION

---

This product has not been developed for the use that needs exclusively high reliability and safety: aerospace apparatus, trunk communication apparatus, nuclear control apparatus, medical apparatus related with life maintenance etc. Therefore, do not use for those purposes.

LE-series models with Wi-Fi function (IEEE 802.11b/g/n) emit radio wave. Please do not use it near a medical device, microwave, high-level electronics, TV, radio, wireless station for mobile communication, or specified low power radio station. To use LE-series in the place where an administrator limits the use of radio devices, follow the instruction of the administrator.

The Wi-Fi module used for the LE-series conforms to SRRC(China), FCC (USA), CE (EU), TELEC (Japan), KCC (Korea), ISED (Canada), NCC (Republic of China), however, as its product (LE-series) the Wi-Fi function is available only in Japan, USA, Canada, and EU nations in compliance with RE directive (2014/53/EU).

To use the product other than above countries, order LE-series without Wi-Fi function. Please contact the sales department for more details.

=== Notice ===

This product contains a lithium-ion battery.

To keep the quality of the battery, LINEEYE does not fully charge the battery.

Before using the battery, please make sure to charge the battery. When you

dispose it, please recycle it in accordance with the local laws and regulations of each country.

2022 by LINEEYE CO., LTD. All rights reserved

# Safety Information



## Read this first !!

This Safety Information includes the following important information in order to not only have you learn the right way to use the analyzer, but also prevent you from causing damage to people and property. Before using,

please read the main contents after you understand the following symbols & marks.



**Warning**

Should the device be used without following these symbols, there is a possibility of accidents, such as a death or a serious injury, occurring.



**Caution**

Should the device be used without following these symbols, there is a possibility of accidents, such as an injury (\*1), and material damage (\*2) occurring.

\*1 : "Injury" indicates injury, burn and electric shock, or the like which does not require hospitalization or the extended hospital visit.









\*2 : "Material damage" indicates damage related to a house, a building, furniture, apparatus, livestock or a pet.







Prohibition





The necessary

 <b>Warning</b>	
	<ul style="list-style-type: none"> <li>Do not disassemble, modify or repair the line monitor This may result in an injury, electric shock, and ignition.</li> </ul>
	<ul style="list-style-type: none"> <li>Turn off the power of analyzer and unplug the cables immediately when emanating smoke, odor or sound. Continuous use may result in an electric shock, injure or ignition.</li> </ul>
	<ul style="list-style-type: none"> <li>Do not use the line monitor if there is inflammable gas. This may result in ignition and explosion.</li> </ul>
	<ul style="list-style-type: none"> <li>Turn off the power and unplug the line monitor immediately when liquid or foreign substance gets into the line monitor. Continuous use may result in ignition, electric shock and malfunction.</li> </ul>
	<ul style="list-style-type: none"> <li>Do not touch the line monitor with wet hand. This may result in an electric shock and malfunction.</li> </ul>
	<ul style="list-style-type: none"> <li>Do not use the battery other than attached Lithium ion battery. Do not short the electrode of the battery. Do not modify, decompose or heat the battery It may cause the ignition and explosion.</li> </ul>
	<ul style="list-style-type: none"> <li>Do not give a strong impact on the product, such as dropping and crashing.</li> </ul>

 Caution

	<ul style="list-style-type: none"><li>• Do not leave the analyzer in the following conditions.<ul style="list-style-type: none"><li>▪ Strong magnetic field, static electricity or dusty place.</li><li>▪ Temperature and humidity above the specification or where dew condensation appears.</li><li>▪ Not flat, or shaking place.</li><li>▪ Place with leaking water or electricity.</li><li>▪ Place affected by direct sun or near the fire.</li></ul></li></ul> <p> Please do not leave the analyzer in the car during the summer.</p>
	<ul style="list-style-type: none"><li>• Do not use at the following situations. The radio wave by the analyzer may cause trouble.<ul style="list-style-type: none"><li>▪ Near a medical device such as cardiac pacemaker or hearing aid.</li><li>▪ Near an automatic controller such as fire-alarm box or automatic door.</li><li>▪ Near a microwave, high-level electronics, TV, or radio.</li><li>▪ Near a wireless station for mobile communications or a specified low power radio station.</li></ul></li></ul>
	<p>Remove the battery from the analyzer, when you throw away.</p>

 Caution

	<ul style="list-style-type: none"><li>• Please follow the instruction for the USB Battery Charger. It may cause the generation of heat, injure, electric shock and malfunction<ul style="list-style-type: none"><li>▪ Do NOT use it for other than AC 100V to 240V.</li><li>▪ Do no use when it brakes.</li><li>▪ Do not twist or step on the cable of charger. (Do not stress the base of cable.)</li><li>▪ Do not place near the heater or put in the fire.</li><li>▪ Do not disassemble, modify the USB Battery Charger or cable.</li><li>▪ Do not curve the cable around the USB Battery Charger.</li><li>▪ Do not put many loads on one electrical outlet.</li></ul></li></ul>
	<ul style="list-style-type: none"><li>▪ Insert it well to the electrical outlet.</li><li>▪ Remove the dust on the AC plug.</li><li>▪ Unplug the charger if you do not use it.</li><li>▪ When unplugging from the outlet, pull out the body straight.</li></ul>

# CONTENTS

---

---

Safety Information	2
--------------------	---

---

Chapter 1 Before Using the Product	6
------------------------------------	---

1.1 Description on This Manual	6
1.2 Unpacking	6
1.3 Functions and Feature	7
1.4 Name of Each Part	9
1.5 Power Supply and Battery	13
1.6 Hand Strap	15

---

Chapter 2 Basic Operation and Set-up	16
--------------------------------------	----

2.1 Power Source ON (Opening Screen)	16
2.2 Top Menu	17
2.2.1 File Manager	18
2.2.2 Record Control	18
2.2.3 System Config	22
2.2.4 Time Settings	26

---

Chapter 3 Online Monitor Function	27
-----------------------------------	----

3.1 Connection	27
3.2 Interface Setup	28
3.3 Filter Setup	29
3.4 Online monitor Configuration	33
3.5 Start and Stop Measurement	35
3.6 Display	36
3.7 Retrieval Function	40
3.8 Trigger Function	42

---

Chapter 4 PoE (Power over Ethernet) Measurement Function	44
---	----

4.1 Connection	44
4.2 PoE Setup	44
4.3 Start and Stop Measurement	45
4.4 Display	45

---

Chapter 5 Delay time measurement function	47
--	----

5.1 Port Selection to Measure	47
5.2 Start and Stop Measurement	48

---

Chapter 6 Statistic Function	49
------------------------------	----

6.1 Connection	49
6.2 Frame Counters	49
6.3 Statistical analysis settings	49
6.4 Start and Stop Measurement	50
6.5 Display	50

---

Chapter 7 Packet Generator Function	51
-------------------------------------	----

7.1 Connection	51
7.2 Transmission settings	51
7.3 Transmission packet summary	51
7.4 Editing the transmission packets	52
7.5 Start and Stop Testing	56
7.6 Test Result	56

---

Chapter 8 Ping Function	57
-------------------------	----

8.1 Connection	57
8.2 Ping Setup	57
8.3 Start and Stop Testing	58
8.4 Display	58

<u>Chapter 9 Port Blink Function</u>	<u>59</u>	<u>Chapter 14 RFC2544 Test Function</u>	<u>74</u>
9.1 Connection.....	59	14.1 How to connect.....	74
9.2 Searching Hub port .....	59	14.2 RFC2544 Settings .....	74
<u>Chapter 10 Cable diagnostic function</u>	<u>60</u>	14.3 Start and End of the Test.....	75
10.1 How to connect.....	60	14.4 Display Screen.....	75
10.2 Setup Cable .....	60	<u>Chapter 15 Save and Load of the Data</u>	<u>78</u>
10.3 Start and Stop Measurement .....	60	15.1 Storage device.....	78
10.4 Display .....	61	15.2 File Management Function .....	79
10.5 Adjustment of NVP value .....	61	<u>Chapter 16 Utility</u>	<u>85</u>
<u>Chapter 11 Link status information</u>		16.1 Key Emulation Software .....	85
	<u>Function</u>	16.2 Data Conversion Software .....	86
	<u>62</u>	16.3 Capture data files while measuring	88
11.1 How to connect.....	62	16.4 PC Remote Control Library.....	89
11.2 Starting and ending measurement ..	62	<u>Chapter 17 Printout Function</u>	<u>90</u>
11.3 Link status information items.....	62	17.1 How to Connect to a Printer.....	90
<u>Chapter 12 Network Emulation</u>		17.2 Hard Copy of Screen Display.....	90
	<u>Function</u>	17.3 Printout of Measurement Data.....	91
	<u>64</u>	<u>Chapter 18 Specifications and</u>	
12.1 Switching the device's			<u>Maintenance</u>
operating mode.....	64	18.1 Specifications of Function and	<u>92</u>
12.2 Connection in Network		Hardware... ..	
Emulation Mode....	65	18.2 Shortcut Keys .....	94
12.3 Network Emulation Settings.....	67	18.3 Expansion of	
12.4 Other Measurement Settings .....	69	Measurement Interface ....	94
12.5 Online Monitor (NE)		18.4 Factory reset .....	95
Function Display Screen.....	70	18.5 Firmware Update.....	95
12.6 Statistical Analysis (NE) Function		18.6 Trouble shooting.....	96
Display Screen .	70	18.7 Warranty and After service.....	98
<u>Chapter 13 BERT Function</u>	<u>71</u>		
13.1 Connection Method.....	71		
13.2 BERT Settings.....	71		
13.3 Start and End of the Test.....	72		
13.4 Display Screen.....	73		

# Chapter 1 Before Using the Product

## 1.1 Description on This Manual

---



### Function for different model



---

- When the performance or function differs depending on the model of the protocol analyzer, [Model number] is described side by side.



### Deception of the Operating Procedure

---

- Printed representation of screen displays in the manual may not be the same as that actually displayed concerning the font and special symbols.
- Descriptions of items of the screen are enclosed in double quotation marks “ ” .
- Reference page is described with .
- Represent key is enclosed in [ ].  
e.g. Press “  ” key. : Press [MENU].
- Successive key or tap operations may be represented by putting their symbols one after another.  
e.g. Press [MENU], then press [0]. : Press [MENU] -> [0].  
e.g. Tap [A], then tap [B]. : Tap [A] -> [B].
- Pressing two keys at the same time is represented by combining their symbols with “+” .  
e.g. Press [SHIFT] and [ESC] at the same time : Press [SHIFT]+[ESC].

## 1.2 Unpacking

---

When you unpack the product, check the items below:

- The product has not been damaged during the transit.
- You have received all the standard accessories listed below.
  - Protocol Analyzer 1
  - Interface Sub-board [SB-GE2] (attached to the analyzer) 1
  - Hand strap ( Already mounted) 1
  - Wide input AC adapter (input: AC100 to 240V, output: DC9V) 1
  - LAN cable 2
  - USB cable (Type A-C) 1
  - External signal I/O cable [LE-4TG] 1
  - Utility CD 1
  - Quick Start Guide 1
  - Carrying bag [LEB-01] 1
  - Warranty 1



The card packed with the product is the user registration card for Japanese customers. For overseas customers, there is a user registration page on our web site.( <https://www.lineeye.com> )

Please let us know if you find any damage to the product or accessories lacking.

- ◆ Utility CD
  - Utility CD contains following files
  - Manual folder : Instruction manual for the analyzer
  - Utility folder : Utility software

## 1.3 Functions and Feature

---

The LE-8500XR / LE-8500X series is a handy-type communication protocol analyzer that can simultaneously measure and test the power supply status of PoE (Power over Ethernet) of one of the lines while simultaneously measuring two lines of Ethernet communication data of 10BASE-T to 1000BASE-T. As it has the online monitor function, packet generate (PG) function, statistical analysis function, PoE judgment function, etc. you can use the analyzer according to the test situation. It can be widely used for communication systems, communication device development, inspection, and failure diagnosis.

- ◆ On-line Monitor Function
  - This function records both the Ethernet communication frame flowing through the network and the transmission/reception time (timestamp) of the frame.
- ◆ PoE Measurement Function
  - This function measures power (watt), voltage and current provided from a PSE device (Power Sourcing Equipment) which supports PoE/PoE+/PoE++(IEEE802.3af/at/bt) to a PD (Powered Device). It can also distinguish types of power supply and appropriate power range.
- ◆ Statistic Function
  - This is a useful feature for analyzing network traffic and the frequency of specific frames.
- ◆ Delay Time Measurement Function
  - This function measures the time difference in reception timing between ports based on the transmission/reception time (timestamp) of the Ethernet communication frame flowing through the network.
- ◆ Packet Generator(PG) Function
  - You can transmit any packet.
- ◆ Ping Function
  - It is able to confirm the linking to the network by transmitting the Ping commands.
- ◆ Port Blink Function
  - You can see which port on the hub the multiple Ethernet cables are connected to.
- ◆ Cable diagnostic Function
  - This function measures cable length and checks if it has any problem.
- ◆ Network Emulation Function
  - Between the ports of this unit, this function performs the test that reproduces a poor network environment where delays and packet loss occur. This function measures cable length and checks if it has any problem.
- ◆ BERT Function
  - This function performs BERT (Bit Error Rate Test).
- ◆ RFC2544 Function
  - This function performs throughput tests, latency tests, frame loss rate tests, and back-to-back tests in accordance with RFC2544.



## Features

---

- 7-inch wide-color LCD with capacitive touch panel
- Supports simultaneous 4-port measurement and timing-delay measurement for 1000BASE-T
- Statistical analysis function that can monitor traffic and the occurrence of specific frames
- Accurate time stamp by the time correction function by GNSS (PPS) signal.
- Supports PoE, PoE+, PoE++ measurement, and analysis of both communication and power.
- Logs can be recorded on a USB flash memory by USB 3.2 (Gen 1) and analyzed by Wireshark.
- B5 size, lightweight and compact body that weighs less than 1 kg



## Optional Accessories

---



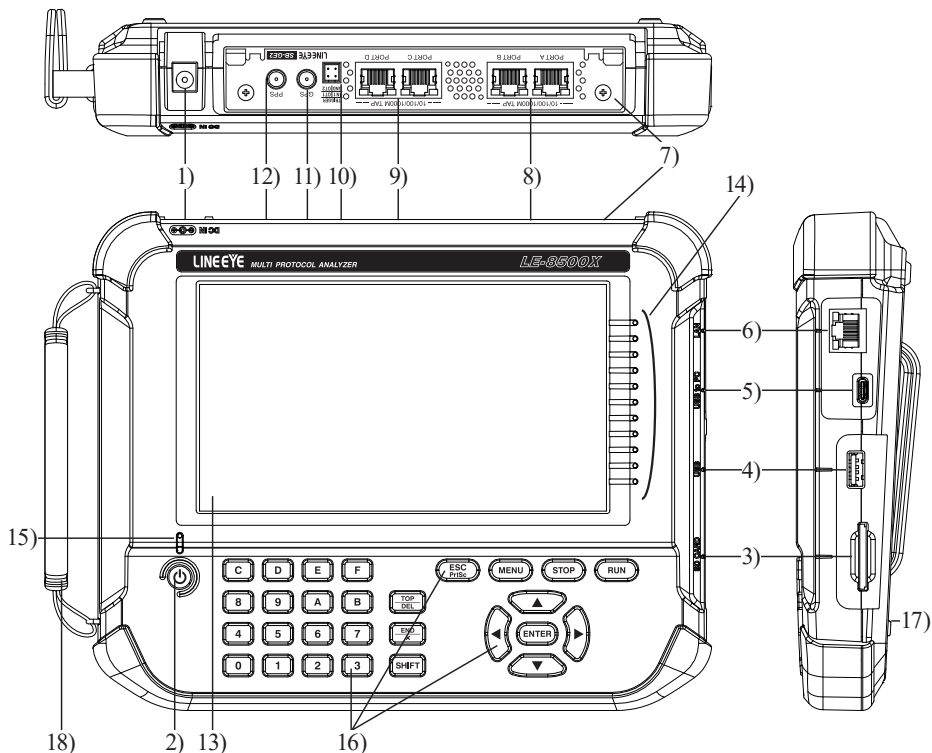

- Expansion kit for RS-232C/530/422/485/TTL communication SB-R2TS1
- GPS active antenna EB-SL-AA170
- Coaxial cable for PPS synchronization LE-SMA-MM-2
- Lithium ion battery pack P-26LW2
- 8GB SDHC card SD-8GX
- 16GB SDHC card SD-16GX
- 32GB SDHC card SD-32GX
- Portable thermal printer SM4-31W

## 1.4 Name of Each Part

### General



Name	Description
1) AC adapter plug	Connects the AC adapter, which serves as a battery charger.
2) Power Switch	Press for about 1 second to turn the power on/off.
3) SD Card Slot	The inlet for a SD/SDHC card.
4) USB Host Port	Connection port for a USB flash drive or Printer.
5) USB Device Port	USB Type-C connector connected to a PC or battery charger.
6) Wired LAN	Connect to a computer via Ethernet LAN. The right LED lights in green when linking. The left LED lights in orange when 1000BASE-T is connected.
7) Inter face Sub -Board	A GbE compatible sub-board SB-GE2 is installed. It can be replaced with a sub-board of other functions.
8) PORT A,B	Used for the online monitor function, delay time measurement function, statistical analysis function, and network emulation function.

9)	PORT C,D	Used for online monitor function, delay time measurement function, and statistical analysis function. When used for the PG function, Ping function, Port blinking function, BERT function or RCF2544 function, the port will be the LAN port.
10)	External Input Terminal	Input/output terminal for TTL level external signal.  3.8 Trigger Function EXT TRG Enable
11)	GPS antenna connector	SMA (female) connector for an active GPS antenna connection. A GPS antenna is to be connected.  2.2.4 Time Settings  3.4 Online monitor Configuration Timestamp synchronization
12)	PPS signal connector	SMA (female) connector for PPS signal input/output. Used for the PPS time synchronization function.  3.4 Online monitor Configuration Timestamp synchronization
13)	7 Inch Color Display	7 Inch Color Display with capacitive touch panel.
14)	Line State LED	Displays the status of the interface to be measured.
15)	Power LED	Lights in green when the power is turned on. Blinking in red when charging battery.
16)	Keypad	Entering commands and other operation.
17)	Battery Cover	Open/close when replacing the battery.  1.5 Power Supply and Battery
18)	Hand Strap	Use to hold the product.

## LED and Display

- Power LED

Light in green during operation. Blink in red while it charges a battery.

Slow charge (when AC adapter is connected) : Blink per 1 sec.

Normal charge (when connected by USB Type-C) : Blink per 1.5 sec.

Fast charge (when connected via other USB) : Blink per 4 sec.

 1.5 Power Supply and Battery

- Line state LED

Tap “LED” at the bottom right of the screen to display the meaning of each LED.

If you tap anywhere in the area while it is displayed, it will be hidden.

You can also switch shown/hidden the display of the meaning of each LED by pressing [SHIFT] + [MENU].



Link A	A Port Link-up
Link B	B Port Link-up
A/B 1000M	A/B Port 1000BASE-T *
A/B 100M	A/B Port 100BASE-TX *
A/B Duplex	A / B Port Full Duplex connection
Link C	C Port Link-up
Link D	D Port Link-up
C/D 1000M	C/D Port 1000BASE-T *
C/D 100M	C/D Port 100BASE-TX *
C/D Duplex	C/D Port Full Duplex connection

\* When both the lights for 1000M and 100M are off it is 10BASE-T.

 The meaning of the display state changes depending on the interface board.

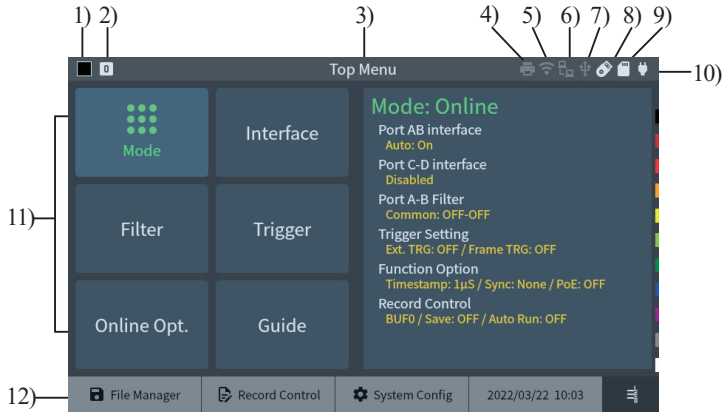
■ Data display window





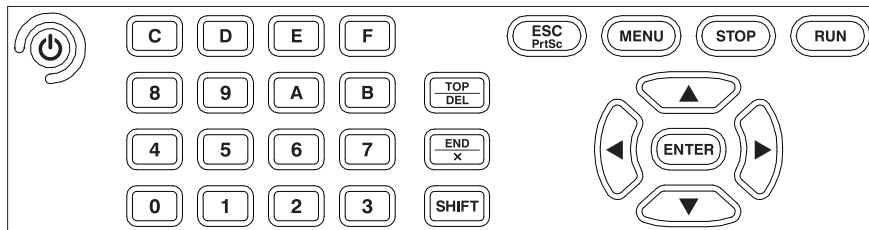

1)	Measuring “●”, Pause “■”
2)	Currently valid capture buffer.  2.2.2 Record Control Recording area
3)	Description of the current window.
4)	USB Printer status (bright display when connection)
5)	Wi-Fi status (bright display when IP address is acquired or access point is ready)  Not displayed on models that do not support Wi-Fi.
6)	Wired LAN status (bright display when IP address is obtained)
7)	Status of USB device port. (Connected when the color is bright, “🔌” is displayed when it is in super speed.)
8)	Status of USB host port. (Bright color when recognizing, red when writing)
9)	Status of SD card slot. (Bright color when recognizing, red when writing)
10)	Estimated battery level is displayed, and “🔋” is displayed when power is supplied from the outside.
11)	Setting items or measured data.
12)	Touch panel for advanced settings.

## Key operation

There is a keyboard to input data and operate commands.



### ■ Keys

Operations	Function
[  ]	Turn ON/OFF the power. Press it for more than 1sec.
[RUN]	Start monitoring, measuring or testing operation.
[STOP]	Stop monitoring, measuring or testing operation.
[MENU]	Return to the top menu.
[ESC]	Return to the previous display Return to the data display from configuration.
[  ], [  ]	Scroll one data line. Move the cursor on the condition setting.
[  ], [  ]	Scrolls the graph display data. Change the setting on the condition setting.
[ENTER]	Apply selected settings.
[0]~[F]	Enter numerical values.
[TOP/DEL]	Delete the entry indicated by the cursor.
[END/X]	Enter the data of "Don't Care".
[SHIFT]	Press to use the expanded alternate function of each key.
[SHIFT]+[TOP/DEL]	Jump to the top of data.
[SHIFT]+[END/X]	Jump to the end of the screen.
[SHIFT]+[ESC]	Save the screen image to the storage device. / Hardware copy
[SHIFT]+[MENU]	Display/hide the description of LEDs.
[SHIFT]+[RUN]	Brighter the LCD back light.
[SHIFT]+[STOP]	Darker the LCD back light.

\* [X]+[Y] indicates the operation of pressing [X] and [Y] together at the same time.

 Shortcut keys are available from [MENU] and [0]~[F].

 18.2 Shortcut Keys

- Touch panel

Following operation is available.

Tap	Tap the screen once to select the setting etc.
Double tap	Tap the screen twice to select and execute the setting.
Swipe	Touch and slide the finger to scroll data.

## 1.5 Power Supply and Battery

This analyzer runs by attached AC adapter, or built-in rechargeable battery.

- Charge the Battery

The built-in lithium-ion battery is charged when powered by the AC adapter or bus-powered from the USB device port.



The charging time will be as follows depending on the usage conditions.

Power supply	Analyzer	Status	Charge Time	Power LED blinking
AC adapter	OFF	—	About 3.5 hours	Approx.1sec cycle
	ON	Stop measuring	Max. 6 hours <sup>*1</sup>	Approx.4sec cycle
		Measuring	No charge	No charge
USB bus power	OFF	Use attached USB cable	Max. 6 hours <sup>*1</sup>	Approx. 4 sec cycle
		Use Type-C battery charger etc. <sup>*2</sup>	About 4.5 hours	Approx.1.5 sec cycle
	ON	—	No charge	No blinking

\*1 : This will not be full charging because of the small amount of current (approx. 160mA).

\*2 : It will be the same when it connects to the PC with a USB port in Type-C connector.

- ☞ This analyzer is not charged in full before shipping. To use the analyzer at the first time, charge it full.
- ☞ Charge the analyzer under the temperature of 5 to 40 °C. It will not start charging below 5 °C.
- ☞ If you are not going to use it for a long term, charge the battery in full. After that, try to charge the battery every 6 months.

- Replace the Lithium ion battery

If the analyzer can no longer drive by the battery, or the service time after charging becomes extremely short, replace the battery.

Disconnect the cables, turn off the analyzer, remove the battery cover, and replace the old battery.

📄 As batteries are consumables, the replacement of a battery will cost you even during the warranty period.

📄 Old battery has to be handled in an appropriate manner.



18.7 Warranty and After service

To replace the battery, purchase LINEEYE Lithium ion battery pack (model: P-26LW2), and do not use any other.

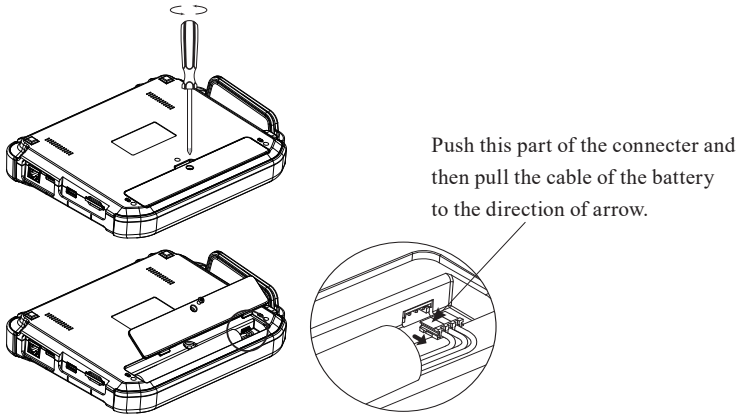

📄 The battery is necessary for protection in the event of a sudden power failure, so be sure to install and use it.

- Lithium primary battery

The clock built into the unit is backed up by the built-in lithium primary battery for about 5 years even when the power is turned off.

📄 If the watch goes wrong or will be reset, replacement of the lithium primary battery at our factory is required. In that case please contact LINEEYE or LINEEYE distributor.

## 1.6 Hand Strap

---

You are able to put and remove this hand strap.



### Put on the hand strap

---

Hand strap is already set in the analyzer when you purchase.

<Remove the hand strap>

- 1) Open the Velcro.
- 2) Remove the belt.
- 3) Remove the hand strap from the analyzer

 Reverse the process when putting on the hand strap.

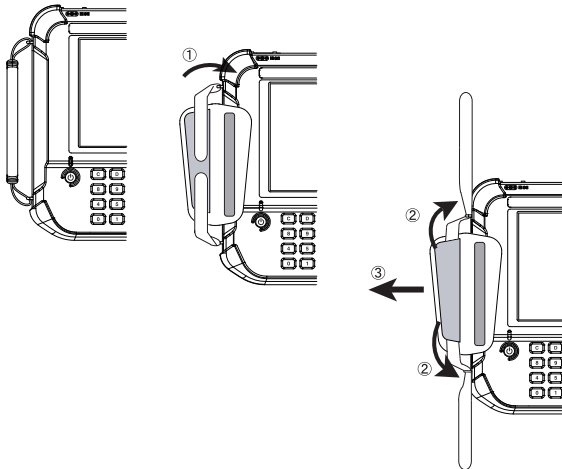

### NOTICE

Put each magic tapes of the belt in the hand strap for 3cm or more.

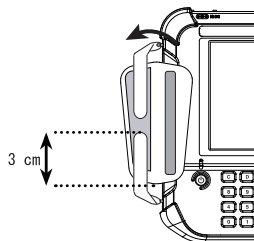

# Chapter 2 Basic Operation and Set-up

## 2.1 Power Source ON (Opening Screen)



### Power Source ON

Press [  ] for about 1 second to start and display the opening screen. It takes about 15 seconds to start. At the first boot, the Japanese-English display language selection screen will be displayed. When it is already set, the top menu screen will be displayed.

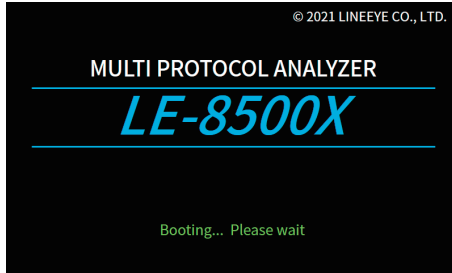

Both LE-8500XR and LE-8500X models are displayed as “LE-8500X”.



### Language (English or Japanese)

At the first boot, you can switch the display language between Japanese and English. To change the already set one, set it at “Language” in the system settings from the top menu screen.



#### 2.2.3 System Config Language

This setting is valid until the system is initialized or the system is recovered from the firmware update operation.

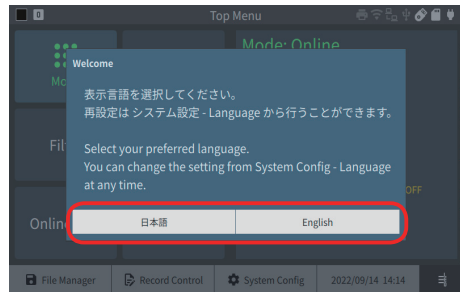

#### 18.4 Factory reset



#### 18.5 Firmware Update



### Power Source OFF

Press and hold the power switch for about 1 seconds to turn off the power of analyzer. The setting data and captured data are saved in the inner memory of analyzer for about 16M byte. To save all data, use the SDHC card or USB flash drive.



#### 2.2.2 Record Control Auto Save Function

## 2.2 Top Menu

Press [MENU] to set the initial settings.

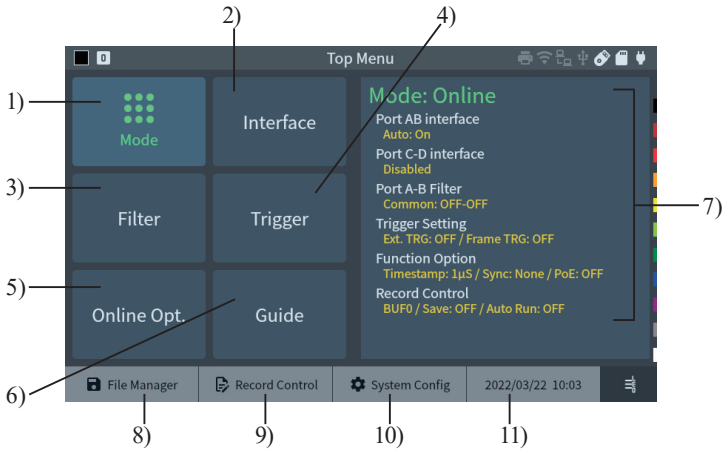

Touch the setting item, or press [ENTER] after selecting the item by [ ▲ ] [ ▼ ] [ ◀ ] [ ▶ ]

Press [ESC] to move to the measurement result display screen.

To switch the measurement mode, tap “Mode” or press [ENTER] while selecting “Mode” and select from the displayed mode list.

You can call up each setting screen by touching “File manager”, “Record Control”, “System Config”, and the current time display at the bottom of the top menu screen.

1)	Switch the measurement mode.	
2)	Set the interface.	3.2 Interface Setup
3)	Set the filter for online monitor mode.	3.3 Filter Setup
4)	Set the trigger for online monitor mode.	3.8 Trigger Function
5)	Set options for online monitor mode.	3.4 Online monitor Configuration
6)	Display the operation guide.	
7)	Displays the currently set measurement mode setting. You can also tap this part to move to the setting change screen.	
8)	Save/read to a file.	2.2.1 File Manager
9)	Configure settings related to the capture buffer for recording measurement data and the save destination.	2.2.2 Record Control
10)	Configure settings related to screen brightness, network, language, firmware update, etc.	2.2.3 System Config
11)	Set the time.	2.2.4 Time Settings

## 2.2.1 File Manager

Save/read to a file.

 Chapter 15 Save and Load of the Data

## 2.2.2 Record Control

Make settings related to the capture buffer for recording measurement data and the save destination.

### ■ Dividing a Capture Buffer

Tap the tab of “Capt. Buffer” and set the capture memory setting of recorded data.

#### ◆ Recording area

The capture memory is 1024 Mbytes.

Select whether a memory is used as one capture buffer or two capture buffers.

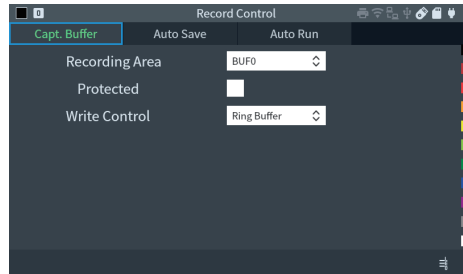

BUF 0 : The whole buffer can be used as one capture buffer.

BUF 1/2 : The capture buffer is divided into two (BUF1 and BUF2) and they are used to measure separate data.

Select when comparing measurement data.

#### ◆ Protected

Mark on the box to prevent data recorded in the buffer memory from being inadvertently overwritten.

 Do not mark on the box when it uses Auto-save function.

#### ◆ Write Control

Select the recording type of capture memory.

Ring Buffer :

When the capture memory is used up, the data is overwritten from the beginning of the memory and the communication data is recorded endlessly.

Full Stop :

When the data is recorded to the end of the capture memory, the measurement is automatically stopped.

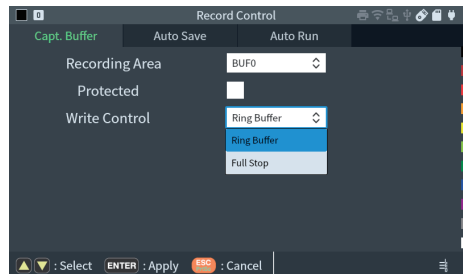

- Auto Save Function

Touch the Auto Save tab to set auto save settings and auto backup settings. By using the auto save setting, the contents of the capture memory (monitored data) can be automatically saved to a storage device such as an SD card as a measurement log file (auto save file) of the specified size continuously for a long time. As you can check the auto-save file which is automatically saved during the communication failure occurrence time by the file management function, it is useful for clarifying communication failures of unknown cause that occur rarely. In addition, as the capture memory loses data when the power is turned off, the latest 16Mbytes of measurement data is automatically backed up to the built-in eMMC at the end of measurement. If you want to automatically save the entire measurement data or delete the data when you turn off the power, change the setting of the auto backup function.

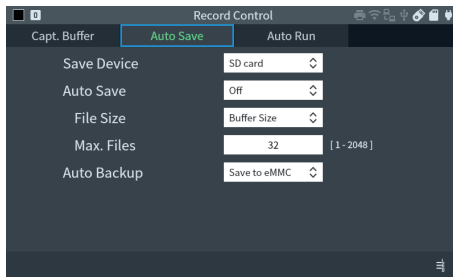

- Preparation and settings

Insert an SD card or USB memory of the appropriate capacity into this unit according to the time you want to record continuously.

If the speed of writing to a storage device is relatively slow to the amount of data to be stored, the writing will not be in time and log data will be lost.

- ◆ Save Device

Select the storage device to save the auto save file. Specify the SD card or USB flash drive inserted in the analyzer.

- ◆ Auto Save

Set the condition of the auto save function.

Off : Auto save function does not work

Restart : Continuous ring recording of auto-save files within the maximum number of files

Max-stop : Saves up to the specified number of auto save files and stops measurement

Append : Continuous ring recording from the file number next to the existing auto save file number

 The name of the auto-save file which is automatically saved is #XXXXXXXX.DT (XXXXXXXX is a sequential number that increases by 1 from 0000000)



- If you set “Restart” or “Max-Stop”, all existing auto save files will be deleted at the start of measurement
- When saving the measurement log for a long time with the auto save function, set the main unit capture memory to the ring buffer. Also, make sure that the trigger condition that stops the measurement is not set.



2.2.2 Record Control Write Control



3.8 Trigger Function

#### ◆ File Size

Specify the file size of the auto save file from 4M, 16M, 64M, 256Mbytes or “Buffer size”. The “Buffer size” will be the same as the capture memory size. Max files

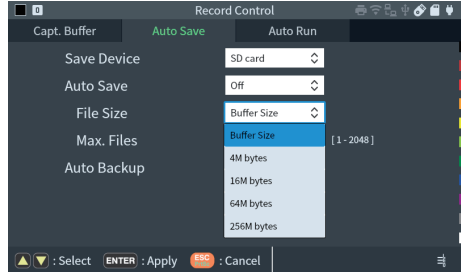

#### ◆ Max. Files

Set the maximum number of auto save files to be automatically saved.



Even if the storage device has free space, it may not be able to store the specified maximum number of files due to media limitations.

#### ◆ Auto Backup

Specify the destination to save the automatic backup data.

The initial value is “Save to eMMC”

Off :

It does not execute automatic backup. Select this when you do not want to keep the measurement data after turning off the power.

Save to eMMC :

Saves the latest 16M bytes of measurement data to the built-in eMMC.

Save to File :

The entire buffer when a measurement is stopped is saved in the storage device specified in “Save Device”.



When “Save to eMMC” is set, the measurement data saved in eMMC is automatically loaded to the capture memory when the power is turned on.



When “Save to File” is set, all measurement data will be saved to a file named @AUTOBU<sub>n</sub>.DAT (n is the number of the used capture memory BUF0, BUF1 and BUF2). Load it manually to use it.

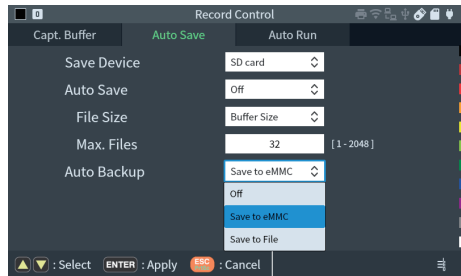

15.2 File Management Function

- Auto Run Function

By using this function, you can repeat the measurement automatically for the specified period by specifying the date and time when the measurement starts and ends. It can start the measurement in conjunction with power-on and automatically finish the measurement at the specified date and time.

- ◆ Auto Run mode

Select the measurement repetition period from Monthly (run monthly), Daily (run daily), or Hourly (run hourly).

- ◆ Run time

Set the date and time when to start the measurement according to the mode. It becomes effective when checked.

- ◆ Stop time

Set the date and time when to finish the measurement according to the mode. It becomes effective when checked.

- ◆ Standby power off

Set whether to enable the function to turn off the power while waiting for the measurement to start. If checked, the power will be turned off automatically after 10 seconds passes if there will be more than 5 minutes between the time when it is turned into the automatic measurement standby state and the start of the next measurement. After that, 3 minutes before the start of measurement, the power is automatically turned on and it is turned into the measurement standby state.

- ◆ Checking the power supply status

Set whether to enable the function to check the power supply from the outside at the start of measurement. When checked, if there is no external power supply when the measurement start time comes the measurement will not start and will remain in the standby state. If “Power off standby” is enabled at the time of this standby state, the power will be turned off automatically after 10 seconds passes.

- ◆ External power on Run

When checked, measurement will start 10 seconds after the power is supplied by the AC adapter. It is used when you want to start measurement in conjunction with the turning on by the external power.

- Control

When “Run Time” is checked, after pressing [RUN] it turns to be wait status until the specified time arrives. To cancel the waiting status press [STOP] or tap “Cancel” .

When the specified time comes, the measurement starts automatically. When the “Stop Time” is checked, the measurement is performed up to the specified time and the measurement automatically stops. This measurement process will be executed repeatedly according to the condition set at “Mode” .

When “External power on Run” is checked, when the power supply by the AC adapter is started while the power of this unit is off, the power will be automatically turned on, and 10 seconds after the boot is completed, the measurement starts automatically without pressing [RUN].

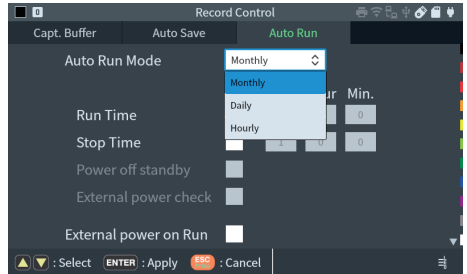
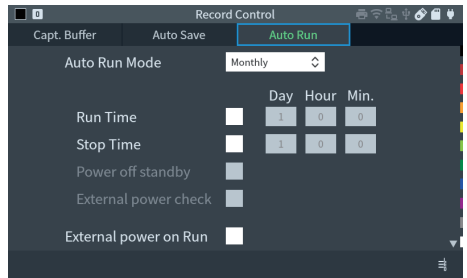

## 2.2.3 System Config

### ■ Display / Power

#### ◆ Backlight brightness

Adjust the brightness of the backlight.

The brighter the backlight, the shorter the running time (higher consumption of current).

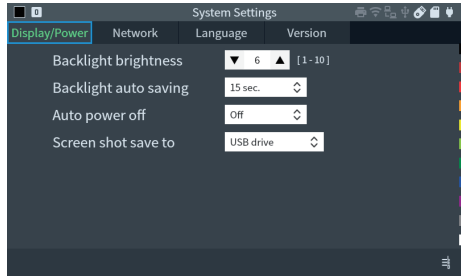

 You can also adjust the brightness of the backlight with [SHIFT] + [RUN] (bright) or [SHIFT] + [STOP] (dark). Use this operation when you want to change the brightness during measurement.

#### ◆ Backlight auto saving

If there is no key operation during the set time, the backlight will be automatically darker to save power consumption. Set “Off” to invalidate this setting.

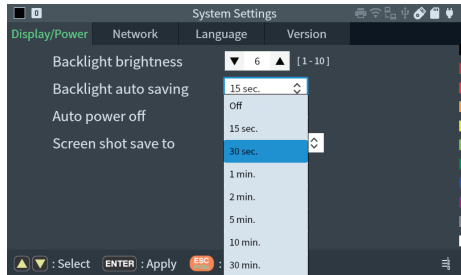

#### ◆ Auto Power Off

Turn off the power if there is no key operation during the set time. Initial setting is “Off” .

 While measuring data, auto-power off function will not work.

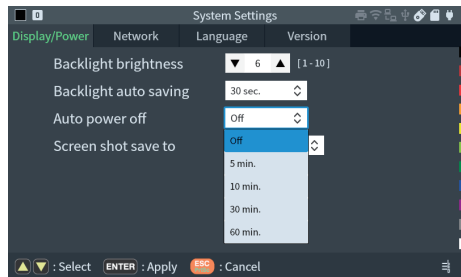

#### ◆ Screen shot save to

The screenshot of the display is saved to the connected external storage device. When both types of storage devices are connected, it is saved to the one specified in this setting.

When you select “USB printer” or “WLAN printer”, it will be hard-copied from the printer.

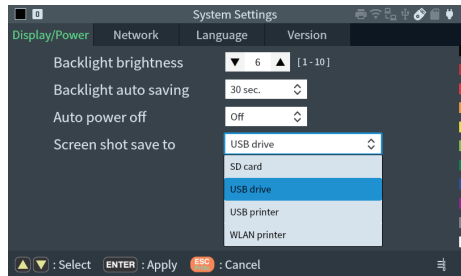

- Network

At the time of shipment, the built-in Wi-Fi module is disabled and no wireless radio waves are output. When connecting to a computer remotely via wireless LAN, you need to set up a Wi-Fi connection.

 The Wi-Fi function is not available for LE-8500X.

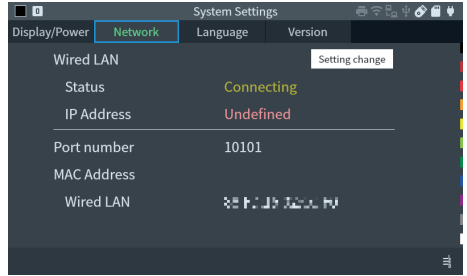

- ◆ Wired LAN

Status            Displays the status of the wired LAN connection.

IP address        Displays the IP address of this unit connected to a wired Ethernet LAN.

Tap “Setting change” to display the setting change screen.

- Port number

Set the port number of the analyzer. The port number is common to Wi-Fi connections. The initial value is “10101”.

- DHCP

Mark on the box when using the network which provides the IP address automatically. Remove the mark if using the specific IP address.

- IP Address

IP Address of the analyzer.

- Subnet mask

Subnet mask of the analyzer.

- Default gateway

Set the default gateway of this device.

- DNS server

Set the address of the DNS server.

- ◆ Wi-Fi connection

Status            Displays the status of the Wi-Fi connection.

IP Address        Displays the IP address of this device connected to Wi-Fi.

Tap “Setting change” to display the setting change screen.

- Port number

Set the port number of analyzer. The initial value is “10101” .

- Mode

Set the Wi-Fi connection method.

Off                The inner Wi-Fi module is invalid.

Station            The analyzer connects to the network via wireless access point.

Access Point     The analyzer itself becomes the wireless access point, and connects to the PC one by one.

## ○ Station Mode

- Port number  
Set the port number of analyzer. The initial value is “10101” .
- SSID  
SSID of wireless access point.
- Password  
Security key (encryption key) of wireless access point.  
 Input characters are changed to “●” for security purpose.
- DHCP  
Mark on the box when using the network which provides the IP address automatically. Remove the mark if using the specific IP address.
- IP Address  
IP address of the analyzer.
- Subnet mask  
Subnet mask of the analyzer.
- Default gateway  
Set the default gateway of this device.
- DNS server  
Set the address of the DNS server.

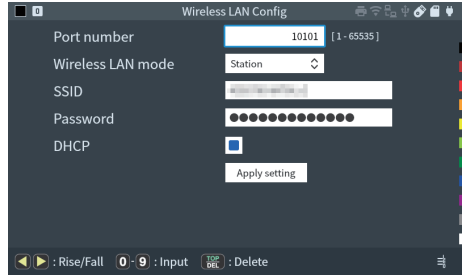

Before changing the IP address and DHCP, try to confirm with the person who is in charge of the network.

Tap “Apply setting” at the end. If the analyzer can connect to the wireless access point successfully, following display will be appeared.

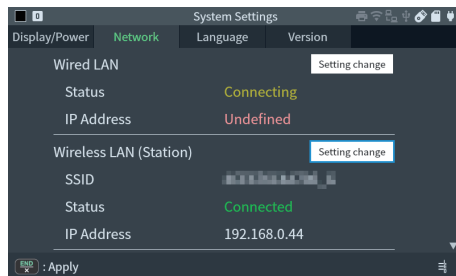

-  If the connection fails, try near a Wi-Fi access point.  
Also, double-check the SSID and password of the Wi-Fi access point.

○ Access point mode

Tap “Apply setting” at the end.

- Port number  
Set the port number of analyzer. The initial value is “10101” .
- Security  
Select the security protocol from OPEN, WPA, WPA2 or WPA/WPA2.  
 If selecting “OPEN” , the password will be invalid.
- SSID  
The initial value is “LE\_#####” . (##### is the serial number)  
If using more than one analyzers, each one should have different SSID.
- Password  
Security key (encryption key) of wireless access point.  
The initial value is “@#####” . (##### is the serial number)
- Channel  
Select the wireless channel (1~11). If selected channel is crowded, try to use another channel.

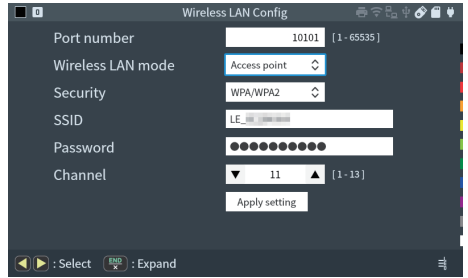

When the wireless access point is set, the status display will be “Active”.

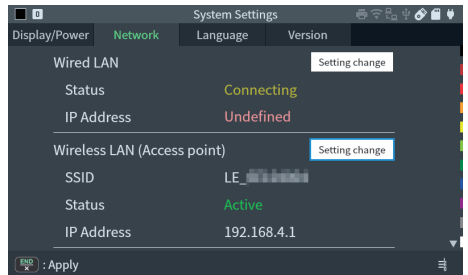

For access point mode, the IP address of analyzer is “192.168.4.1” and this cannot be changed. This , change the IP address of the target device (PC etc.) to the one within the same network group (exp. 192.0.168.4.2), or change the setting of the DHCP server to receive the IP address from analyzer.

■ Language

Select a language (English or Japanese).

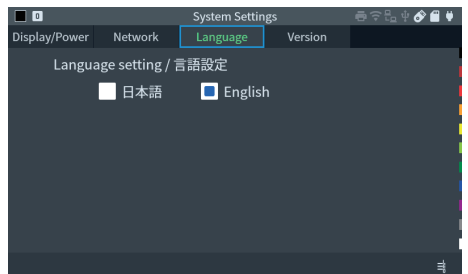

- Version

It displays the current firmware version of the analyzer, executes the firmware update mode, and initializes the main unit.

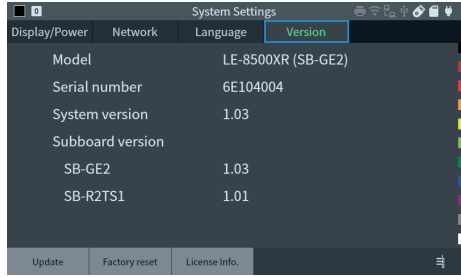

 18.5 Firmware Update

 18.4 Factory reset

## 2.2.4 Time Settings

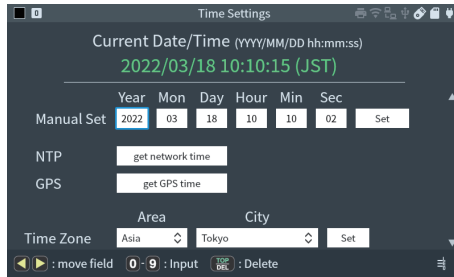

Current time and date are displayed in the screen.

Set the time in order of Hr(24hour)/Min/Sec, and date in order of Yr/Mon/Day.

- Manual Set

Manually set the date and time. Use [ ◀ ] [ ▶ ] to move the cursor, use [0] to [9] to enter, and press “Set” to confirm.

- NTP

Set the current time using an NTP server on the Internet. You need to set the network settings so that it can use Internet communication.

 2.2.3 System Config Network

- GPS

Set the current time using GPS. The GPS antenna must be connected. When the setting fails, move the antenna to a location with good reception, then wait a while, and try again.

- Time Zone

Specify the time zone.

 Information of time and date is used for time stamp and Auto start/stop. Make sure to input the current time and date precisely.

# Chapter 3 Online Monitor Function

Online monitor function is to capture LAN frames passing over a network along with time stamp information of the frame and record it into the Buffer memory.

Select "Online" from Mode on the top menu screen.

## 3.1 Connection

Connect the LAN cables (in which the communication data between the target devices run) with each port as follows. When you need additional cables for branch connection, use the attached LAN cable or a straight cable of the category 5e or later.

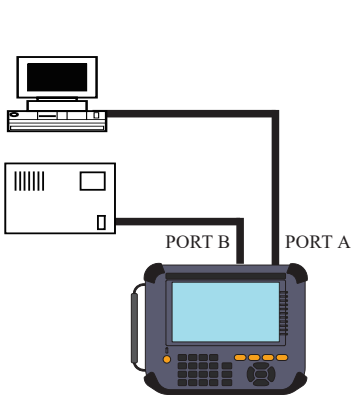

When you monitor 2 ports .

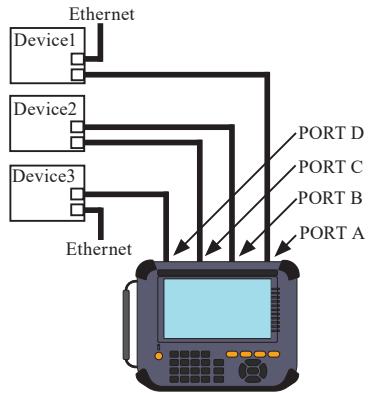

When you monitor 4 ports of EtherCAT etc

When it is in online-monitoring, it will be as shown in the figure below.

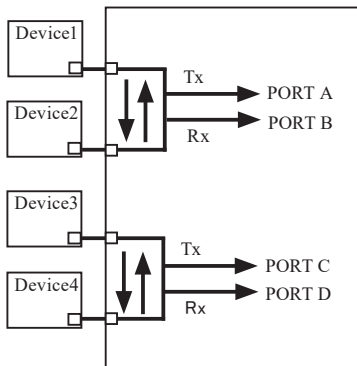

Tx between TAP A and B is recorded as PORT A, Rx is recorded as PORT B, Tx between TAP C and D is recorded as PORT C, and Rx is recorded as PORT D.

In TAP mode, the analyzer receives the packets of Port A and Port B once, captures them, and sends the packets to the opposite port.  
 Delay is occurred when it passes through the TAP circuit in the analyzer.  
 Delay time is approx. 1.3 $\mu$ s-1.5 $\mu$ s for 1000BASE-T/100BASE-TX and 5 $\mu$ s for 10BASE-T.  
 Even if the power of the analyzer is turned off, it has a fail-safe mode in which the internal wiring is switched and the devices are directly connected to each other. However, if the power is turned off, the network will be disconnected for a moment.

## 3.2 Interface Setup

After selecting the measurement mode from the top menu, tap “Interface” and set the interface type to be measured on the interface screen. Ports A-B and C-D can be configured individually.

- Auto Negotiation

Select On/Off of Auto Negotiation. When the devices connected to the ports are compatible with Auto Negotiation, select “On” or “Select” . When you want to use by fix, select “Off” .

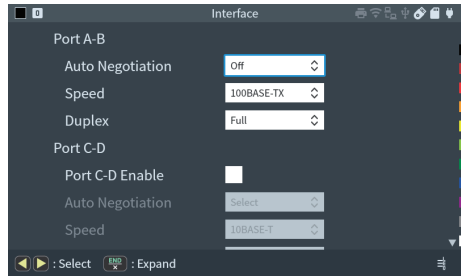

<Off>

No Auto Negotiation setting. Select the same “Speed” and “Duplex” as ones of measurement target devices.

If selected configurations are not correct, analyzer cannot measure data correctly.

<Select>

Although it is a setting with auto-negotiation, you can specify the speed standard and communication method.

If selected configurations are not correct, analyzer cannot measure data correctly.

<On>

It is a setting with auto-negotiation. The link speed standard and communication method are automatically determined when connecting.

- Port C-D Enable

Check this first when using ports C-D.

- Operation mode\*

Tap “switch” to switch the operation mode of this unit to network emulation mode, which reproduces network delays, etc.

Rebooting is required to switch operation modes.

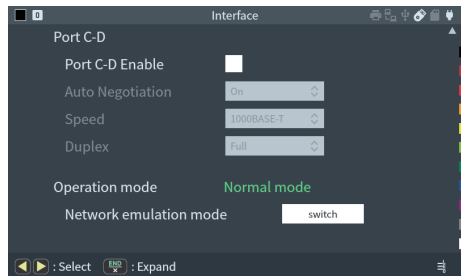

Chapter 12 Network Emulation Function

\* Network emulation mode is available in system version V1.12 and later.

### 3.3 Filter Setup

From the online monitor mode screen, tap “Filter” to set the filter conditions for capturing only specific frames. Filters can also be set individually for Tx and Rx.

There are two filter settings for ports A-B and C-D, and you can select which port to set on the tab.

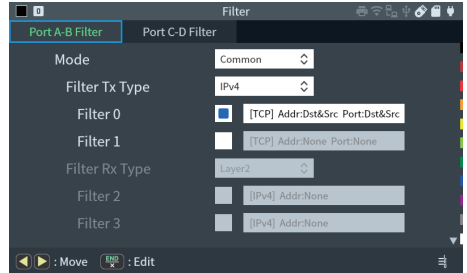

- Mode

Select the filter configuration mode for Rx (only Tx side filter has the setting).

Common : Applies the configuration of Tx.

Separate : Applies the configuration of Rx.

The configuration for Rx is available when you select Separate.

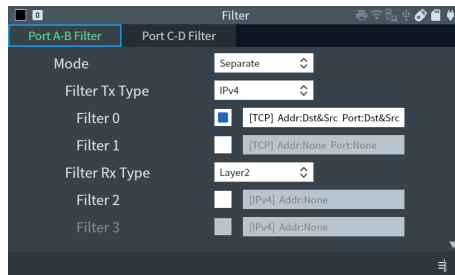

- Type

Select the filter type.

Layer2 : Layer 2 field

IPv4 : IP(Version4) field

- Filter

Select valid/invalid of the filter.

When the filter of smaller number is No effect the filter of larger number also turns to be No effect.

e.g. ) When the filter 0 is No effect, the filter 1 also turns to be No effect.

## <IPv4>

Set the conditions of IP header for IPv4 frame.

- Protocol Field

Select the protocol field from ICMP, IGMP, TCP, UDP, Custom (specify the number) and All.

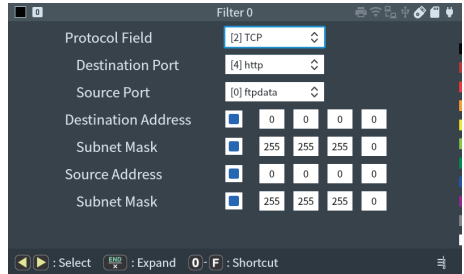
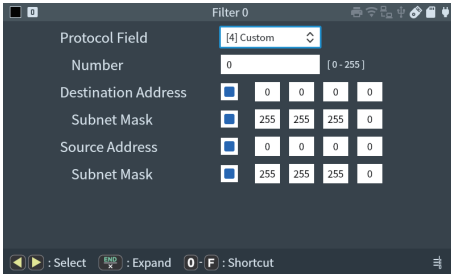

- Number

Input the protocol number, in the case of the selecting “ Custom ” at “ Protocol field ” .

- Destination Port

Input the destination port number when TCP or UDP is selected in the Protocol field.

- Source Port

Input the source port number when TCP or UDP is selected in the Protocol field.

 If the option is added to the IP header of the frame, the function of “source Port” and “Destination Port” will not work properly.

- Destination Address

If checked, you can specify the destination (Dst) address.

- Source Address

If checked, you can specify the destination (Src) address.

- Subnet Mask

You can specify it by checking it.

The target range is the network address obtained from the bitwise AND of this value and the destination (Dst) and destination (Src) address specified values.

## <Layer2>

Set the conditions of MAC header for target frame.

- Type Field  
Select the type field from IPv4, ARP, NetBios, IPv6, EtherCAT, Custom (number specified), ALL (not specified).
- Number  
Input the type number, in the case of the selecting “Custom” at “Type field ” .
- Destination Address  
If checked, you can specify the destination (Dst) address.
- Source Address  
If checked, you can specify the source (Src) address.

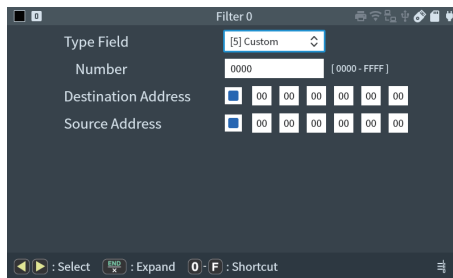

## <Example of IPv4 setting>

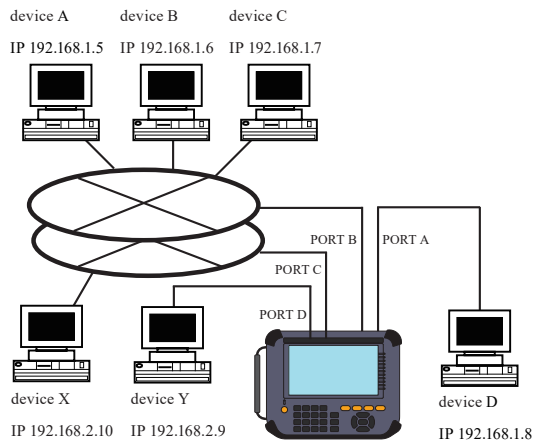

- Monitoring example of TCP/IP frames between Device A and D by filtering.

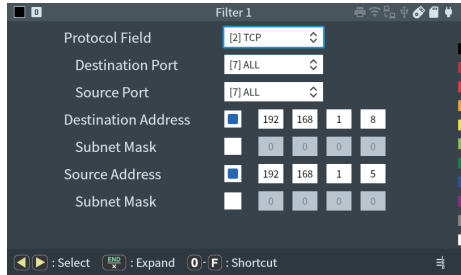
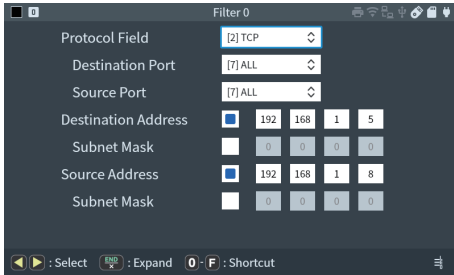
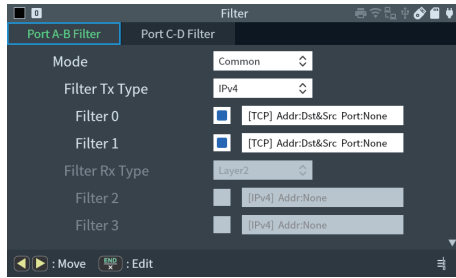

The filter 0 is configured to monitor TCP frames sent from the device D to device A and the filter 1 is configured to monitor TCP frames sent from the device A to device D. Configures this setting between port A-B.

- An example of the configuration to monitor only the UDP protocol communication between the devices X and Y which belong to the network address "192.168.2"

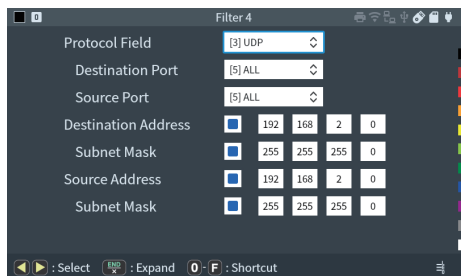
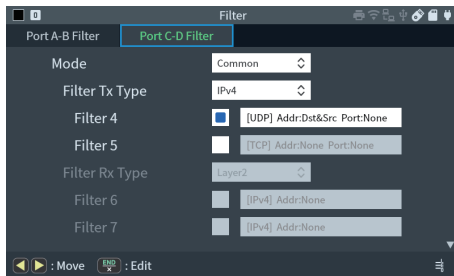

It is configured by filter 4 to monitor only the frames of UDP protocol which have "192.16.2" for the network address part of both source IP and destination IP.

## 3.4 Online monitor Configuration

From the online monitor mode screen, tap “Online Opt.” to enter the settings screen for data recording.

### ■ Timestamp Resolution

Records the time when the packet is received. Select the resolution from 10us/1us/8ns. When you execute a long-term measurements, the internal 46-bit counter may go around with the minimum resolution setting. In that case, set the resolution coarsely.

[ Maximum measurement time ]

8ns : about 6.5 days

1us : about 2.2 years

10us : about 22 years

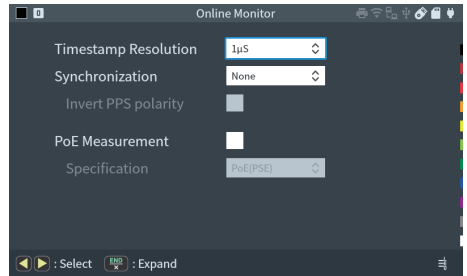

### ■ Synchronization

Set when synchronizing the time stamp to a certain condition.

None Uses the built-in RTC of analyzer

GPS time Synchronize with PPS signal obtained from GPS

Ext. PPS Synchronizes with the PPS signal input from the PPS terminal

When either synchronization is enabled, it takes 3 to 4 seconds to actually start the measurement because the synchronization work starts at the start of the measurement. If a valid PPS signal cannot be received during that time, an error will occur and the measurement will not start. Be especially careful when using the automatic measurement function.

For external PPS synchronization, the measurement start time is the positive second (○○ seconds .000000000) closest to the current internal clock time.

If you want to synchronize the data time stamp with UTC as well as the relative time after the start of measurement, you need to set the built-in clock to an error of less than 0.5 seconds in advance using NTP etc.

### ■ Invert PPS polarity

When not checked, the time will be adjusted by detecting the falling edge. Do not check when the PPS signal is output by another LE-8500X series or a PPS signal output device that outputs the time at the falling edge.

Check this when using a PPS signal output device that outputs the time at the rising edge.

### ■ PoE Measurement

PoE measurement is performed at the same time with the measurement of Ethernet LAN communication frame.

For simultaneous PoE measurement, the PoE measurement cycle is fixed at 20msec.

Depending on the Ethernet LAN communication data rate, the number of PoE data points drawn in the data view may be temporarily reduced.

### ■ Specification

Select the PoE specification.

< About connection and setting of time stamp synchronization function >

The timestamp synchronization feature has the following connections.

- Synchronize by GPS antenna

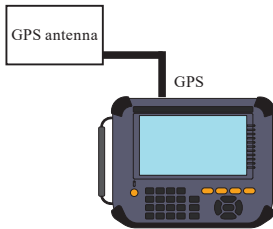

Synchronizes the LE-8500X's time stamp using a GPS active antenna.  
Then optional GPS active antenna is needed.

Set "GPS time" to "Synchronization" on LE-8500X.

- Share GPS antenna with two units

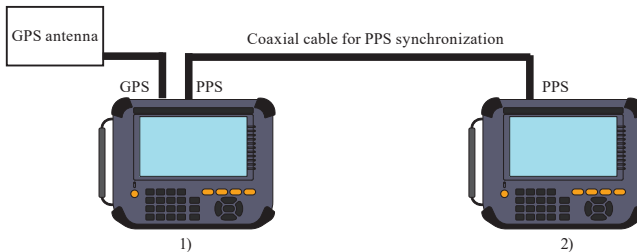

Synchronizes the time stamps of two LE-8500Xs with one GPS active antenna.  
Optional GPS active antenna and PPS cable are needed.

For LE-8500X 1), set "GPS time" to "Synchronization".

For LE-8500X 2) set "Ext. PPS" to "Synchronization".

Also, uncheck "Invert PPS polarity".

 Do not connect the GPS antenna to 2).

- Usage of an external PPS device

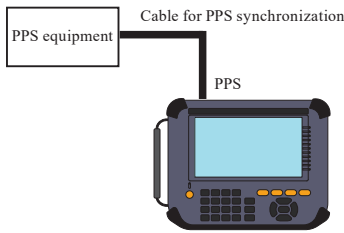

To synchronize the time stamp of LE-8500X with the PPS signal output device, an optional PPS cable is needed.

For LE-8500X set “Ext. PPS” to “Synchronization”.

Check “Invert PPS polarity” according to the PPS signal output device to be used.

Do not connect a GPS antenna.

## 3.5 Start and Stop Measurement

---

- Starting measurement

Press [RUN]. The display at the top left of the screen changes from “” to “”, and the data is captured in the capture buffer.

Time	Len	P	Source	Dest	Protocol
19:58.212858	60	A	00:17:C8:4C:ED:94	FF:FF:FF:FF:FF:FF	ARP
19:58.214417	60	A	00:17:C8:4C:ED:94	FF:FF:FF:FF:FF:FF	ARP
19:58.485028	60	A	10:6F:3F:B3:56:DC	FF:FF:FF:FF:FF:FF	[8899]
19:58.580697	60	A	00:24:A5:4B:8A:86	FF:FF:FF:FF:FF:FF	[8899]
19:58.693222	216	A	192.168.0.24	239.255.255.250	UDP
19:58.925640	216	A	192.168.0.27	239.255.255.250	UDP
19:59.214834	60	A	00:17:C8:4C:ED:94	FF:FF:FF:FF:FF:FF	ARP
19:59.214865	60	A	00:17:C8:4C:ED:94	FF:FF:FF:FF:FF:FF	ARP
19:59.222225	92	A	192.168.0.200	192.168.0.255	UDP
19:59.693984	216	A	192.168.0.24	239.255.255.250	UDP
19:59.940985	216	A	192.168.0.27	239.255.255.250	UDP
19:59.998638	82	A	192.168.0.5	192.168.0.255	UDP
20:00.216816	60	A	00:17:C8:4C:ED:94	FF:FF:FF:FF:FF:FF	ARP
20:00.484982	60	A	10:6F:3F:B3:56:DC	FF:FF:FF:FF:FF:FF	[8899]
20:00.580662	60	A	00:24:A5:4B:8A:86	FF:FF:FF:FF:FF:FF	[8899]

- Stop measurement

Press [STOP] to finish the measurement. Or it also stops measurement when the trigger condition has been met.

## 3.6 Display

Press [ENTER] key. Frame display, can be changed to, Detailed display .

- Frame display

It displays the LAN frames with the time stamp information on the screen.

Time stamp

Source address

Destination address

Protocol

mm:ss.ussec	Len	P	Source	Dest	Protocol
32:17.445902	215	A	192.168.0.7	239.255.255.250	UDP
32:18.071925	60	A	192.168.0.20	192.168.0.106	TCP
32:18.073329	60	B	192.168.0.106	192.168.0.20	TCP
32:18.123813	60	A	192.168.0.20	192.168.0.106	TCP
32:18.815690	60	A	192.168.0.20	192.168.0.106	TCP
32:18.816303	60	B	192.168.0.106	192.168.0.20	TCP
32:18.837183	60	B	192.168.0.106	192.168.0.20	TCP
32:18.837412	60	A	192.168.0.20	192.168.0.106	TCP
32:19.222895	60	A	00:24:A5:4B:8A:86	FF:FF:FF:FF:FF:FF [8899]	
32:19.420985	60	A	10:6F:3F:B3:56:DC	FF:FF:FF:FF:FF:FF [8899]	
32:20.767703	60	A	192.168.0.20	192.168.0.106	TCP
32:20.769108	60	B	192.168.0.106	192.168.0.20	TCP
32:20.811334	60	A	192.168.0.20	192.168.0.106	TCP
32:21.222682	60	A	00:24:A5:4B:8A:86	FF:FF:FF:FF:FF:FF [8899]	
32:21.343442	60	A	192.168.0.20	192.168.0.106	TCP

Time Resolution    Position Jump    Detail    PoE    Search

“Time Resolution”

ss.nsec or mm:ss.ussec \* 1

hh : mm : ss . msec

MM / DD hh : mm : ss

YY / MM / DD hh : mm

Δ time(sec) \* 2

\*1: Displayed resolution of time stamp is set in the configuration.

\*2: Elapsed time from previous frame.

Press [SHIFT]+ “Relative Time” to start the time stamp from zero when it starts measuring.

You can scroll the screen by [▲] [▼] or swipe.

- PoE

When simultaneous PoE measurement is enabled, the screen switches to the PoE data display. While the measurement is stopped, the display position automatically shifts to the PoE data closest to the time stamp.

4.4 Display

mm:ss.ussec	Len	P	Source	Dest	Protocol
32:17.445902	215	A	192.168.0.7	239.255.255.250	UDP
32:18.071925	60	A	192.168.0.20	192.168.0.106	TCP
32:18.073329	60	B	192.168.0.106	192.168.0.20	TCP
32:18.123813	60	A	192.168.0.20	192.168.0.106	TCP
32:18.815690	60	A	192.168.0.20	192.168.0.106	TCP
32:18.816303	60	B	192.168.0.106	192.168.0.20	TCP
32:18.837183	60	B	192.168.0.106	192.168.0.20	TCP
32:18.837412	60	A	192.168.0.20	192.168.0.106	TCP
32:19.222895	60	A	00:24:A5:4B:8A:86	FF:FF:FF:FF:FF:FF [8899]	
32:19.420985	60	A	10:6F:3F:B3:56:DC	FF:FF:FF:FF:FF:FF [8899]	
32:20.767703	60	A	192.168.0.20	192.168.0.106	TCP
32:20.769108	60	B	192.168.0.106	192.168.0.20	TCP
32:20.811334	60	A	192.168.0.20	192.168.0.106	TCP
32:21.222682	60	A	00:24:A5:4B:8A:86	FF:FF:FF:FF:FF:FF [8899]	
32:21.343442	60	A	192.168.0.20	192.168.0.106	TCP

Time Resolution    Position Jump    Detail    PoE    Search

- Detailed display

Display the details of the frame, which is displayed on the top of the Frame Display.

“Dump” : The translation view can be changed to the HEX dump view.

- Translation view

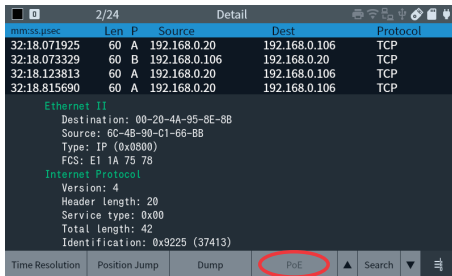

Refer to the specifications of each protocol to understand the contents of the protocol.

If you are using timestamp synchronization, you can check the synchronization status in the GPS/PPS Sync.Status item added to the detail view. Immediately after the start of measurement, as the synchronization is not completed it will be NG, and after synchronization is completed it will be OK.

- HEX dump view



The target frame for dump view. It is able to scroll data by swiping the screen.

Dump display of Ethernet frame. Scroll frames by [ ▲ ] [ ▼ ] keys.

It is possible that there is some capturing loss for a large amount of data(“OVERRUN” will be displayed in the screen.)When opening Auto Save log data, the packet right above the “OVERRUN” may be broken off midway, in that case, it can not be displayed correctly.

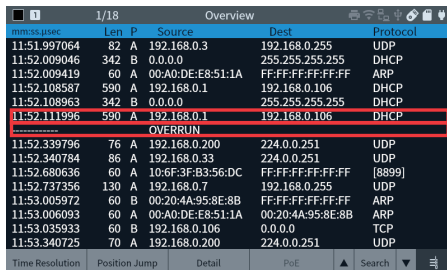

Broken off Data packet can not be displayed correctly.

“OVERRUN” display

- Split Display

The data stored in BUF1 and BUF2 can be displayed simultaneously on the measurement data screen.

By comparing the two measurement data, analysis can be performed more efficiently, such as detecting differences in the event of a failure.

- 1) Save the measurement data in BUF1 or BUF2. On the recording control setting screen, set the buffer to be used to either BUF1 or BUF2, and prepare the measurement data by executing the measurement or loading the file.
- 2) Press [SHIFT] + “Change Buffer” to prepare another measurement data in the other buffer by executing the measurement or loading a file.
- 3) You can display both buffers on one screen by pressing [SHIFT] + “Split Display”.

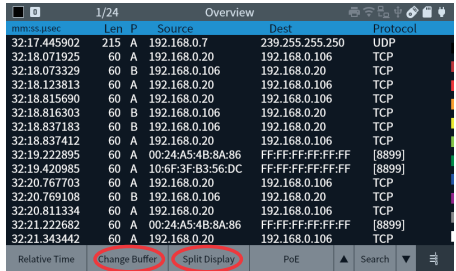

The two data screens scroll individually, but if you want to scroll at the same time, tap “SYNC”.

You can scroll two data at the same time by pressing the [▲] [▼] keys.

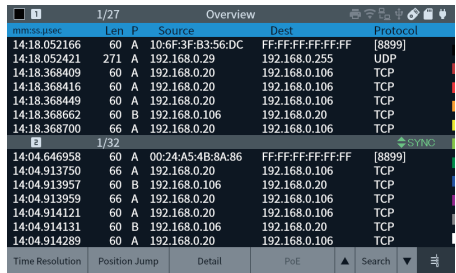
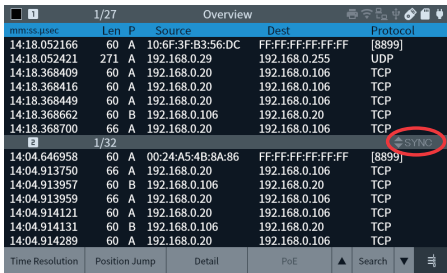

- Position Jump

Display from the specified frame.

Tap “Position Jump” and enter the frame number to jump to.

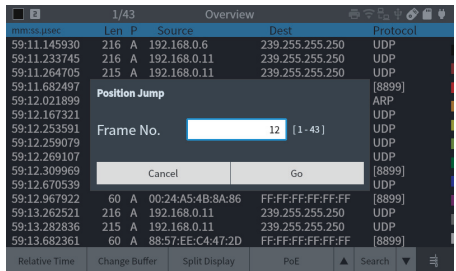

- Mark & Jump

By marking a frame you can jump to the frame with a single key.

Marks can be added up to 9 places.

When you just made a jump to mark, by the single key you can return to the frame where it was before the mark jump.

Mark set : [SHIFT] + [1]-[9]

Jump to Mark : [1]-[9]

Canceling the jump to Mark : [0]

The marked frame shows the same M1 to M9 as the given key.

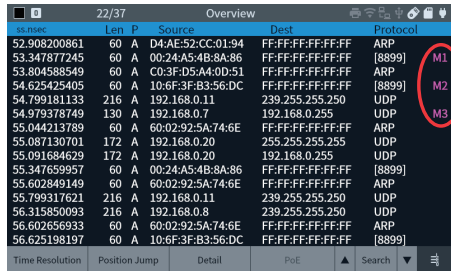

Time	Source	Len	P	Source	Dest	Protocol	Mark
52.908200861	60	A		D4:AE:52:CC:01:94	FF:FF:FF:FF:FF:FF	ARP	M1
53.347877245	60	A		00:24:A5:4B:8A:86	FF:FF:FF:FF:FF:FF	[8899]	
53.804588549	60	A		C0:3F:D5:A4:0D:51	FF:FF:FF:FF:FF:FF	ARP	M2
54.625425405	60	A		10:6F:3F:B3:56:DC	FF:FF:FF:FF:FF:FF	[8899]	
54.799181133	216	A		192.168.0.11	239.255.255.250	UDP	M3
54.979378749	130	A		192.168.0.7	192.168.0.255	UDP	
55.044213789	60	A		60:02:92:5A:74:6E	FF:FF:FF:FF:FF:FF	ARP	
55.087130701	172	A		192.168.0.20	255.255.255.255	UDP	
55.091684629	172	A		192.168.0.20	192.168.0.255	UDP	
55.347659957	60	A		00:24:A5:4B:8A:86	FF:FF:FF:FF:FF:FF	[8899]	
55.602849149	60	A		60:02:92:5A:74:6E	FF:FF:FF:FF:FF:FF	ARP	
55.799317621	216	A		192.168.0.11	239.255.255.250	UDP	
56.315850093	216	A		192.168.0.8	239.255.255.250	UDP	
56.602656933	60	A		60:02:92:5A:74:6E	FF:FF:FF:FF:FF:FF	ARP	
56.625198197	60	A		10:6F:3F:B3:56:DC	FF:FF:FF:FF:FF:FF	[8899]	

If you execute a numbering operation to a mark where there is the same number, the mark will be deleted.

If you set a mark of a different number, it will overwrite the existing mark.

## 3.7 Retrieval Function

With the search function, you can find specific data.

The search conditions can be set by tapping “Search” .

Tap “ Find Next.” “ Find Prev.” From the condition setting screen to execute the search in that direction.

Press “▼” “▲” on the frame display screen to continue the search.

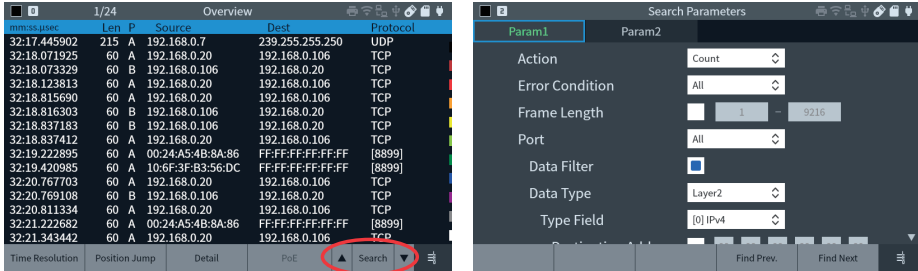

- **Action**  
Specify on the Param 1 tab.  
Select “Display” to jump to the frame that meets the conditions.  
Select “Count” to display the number of frames that satisfy the conditions before or after the current cursor position.
- **Param 2 Valid**  
Condition 2 Specify on the Param 2 tab.  
By checking it, you can set condition 2 which is to be searched by condition 1 and OR condition.
- **Error Condition**  
Select this when you want to search for the frame where the error occurred.
- **Frame Length**  
When you want to specify the frame length condition, check it and enter the range. Minimum 1 to maximum 9216. Specify a length that does not include FCS.
- **Port**  
Select to specify a frame of a specific LAN port.
- **Data Filter**  
When you want to search by the condition of the frame contents, check it and enable the items after this.
- **Data Type**  
Select the type to search from “Layer2” or “IPv4”.

## <Layer2>

Set the conditions of MAC header for target frame.

- Type Field

Select the type field from IPv4, ARP, NetBIOS, IPv6, EtherCAT, Custom (specify the number) and All.

- Number

Input the type number, in the case of the selecting “Custom” at “Type field” .

- Destination Address

By checking it, you can specify the destination (Dst) address.

- Source Address

By checking it, you can specify the source (Src) address.

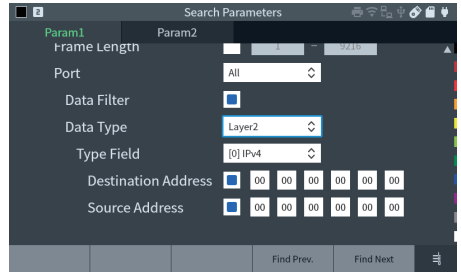

## <IPv4>

Set the conditions of IP header for IPv4 frame.

- Protocol Field

Select the protocol field from ICMP, IGMP, TCP, UDP, Custom (specify the number) and All.

- Number

Input the protocol number, in the case of the selecting “ Custom ” at “ Protocol Field ” .

- Destination Port

Input the destination port number when TCP or UDP is selected in the Protocol field.

- Source Port

Input the source port number when TCP or UDP is selected in the Protocol field.

- Destination Address

By checking it, you can specify the destination (Dst) address.

- Source Address

By checking it, you can specify the source (Src) address.

- Subnet Mask

By checking it you can specify the subnet mask.

The target range is the network address obtained by the bitwise AND calculated by this value and the specified values of destination (Dst) and source (Src) address.

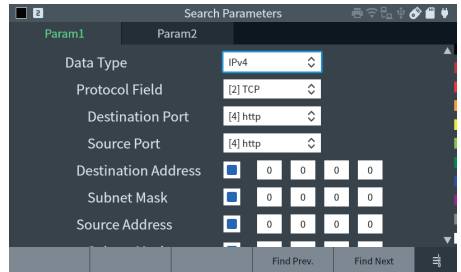

## 3.8 Trigger Function

Triggers can be made by matching the specified conditions of the frame or by an external input signal. A trigger can automatically stop the measurement. It is also possible to count the number of frames that match the conditions.

 1-2 extra data may be recorded before the actual stop.

Tap “Trigger” from the top menu screen and set the trigger conditions on the trigger setting screen.

- **EXT TRG Enable**  
When checked, the L level (TTL level) of the external signal connected to IN1 of the external input/output terminal will be the trigger.

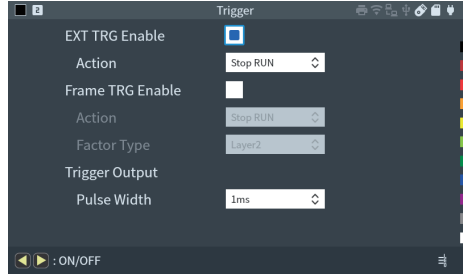

- **Frame TRG Enable**  
Enable/disable the frame detection trigger.

• Action

Select “Stop RUN” to stop the measurement when a trigger occurs or “Count” to count the number of triggers.

• Factor Type

Select the frame type from “Layer2” or “IPv4”.

- **Trigger Output**

Set the L level (TTL level) signal width to be output to OUT1 of the external input/output terminal when a trigger occurs.

<Layer2>

Configuration of the MAC header of specified frames.

- **Type Field**  
Select the type field from IPv4, ARP, Net Bios, IPv6, Custom(specified number), or ALL(without specifying).

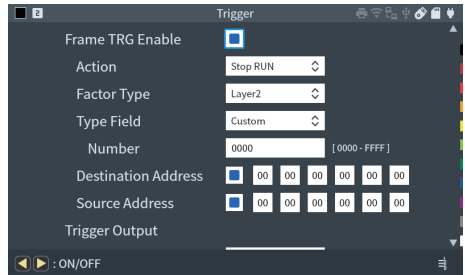

- **Number**

Enter a type number when you have chosen “ Custom ” at Type field.

- **Destination Address**

By checking it, you can specify the destination (Dst) address.

- **Source address**

By checking it, you can specify the source (Src) address.

## <IPv4>

Configuration of the IP header of IPv4 frames.

- Protocol Field

Select the protocol field from ICMP, IGMP, TCP, UDP, Custom(specified number), or ALL(without specifying).

- Number

Enter a protocol number when you have chosen “Custom” at Protocol field.

- Destination Port

Specify the destination port number when TCP / UDP is selected in the protocol field.

- Source Port

Specify the source port number when TCP / UDP is selected in the protocol field.

The destination (Dst) and source (Src) ports do not work well if the frame's IP header has options.

- Destination Address

By checking it, you can specify the destination (Dst) address.

- Source Address

By checking it, you can specify the source (Src) address.

- Subnet Mask

By checking it you can specify the subnet mask.

The target range is the network address obtained by the bitwise AND calculated by this value and the specified values of destination (Dst) and source (Src) address.

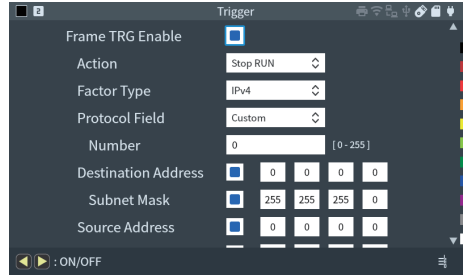

Frame display screen when a trigger occurs

“T” is displayed for the frame where the trigger occurred. If the trigger action is set to “count”, the number of how many triggers occurred will be displayed on the screen.

Time	Len	P	Source	Dest	Protocol
10:06.412167	86	A	34:9F:7B:46:41:09	33:33:00:00:01:51	IPv6
10:06.413309	86	A	34:9F:7B:46:41:09	33:33:00:01:00:03	IPv6
10:06.414337	86	A	34:9F:7B:46:41:09	33:33:00:00:00:0C	IPv6
10:06.432499	130	A	28:39:26:9C:1A:6D	33:33:00:00:00:16	IPv6
10:06.702115	150	A	5C:E4:D1:1E:2F:77	33:33:00:00:00:15	IPv6
10:06.827331	150	A	D8:CO:AG:9A:35:15	33:33:00:00:00:16	IPv6
10:08.865083	60	A	BC:5C:4C:A8:8B:C5	FF:FF:FF:FF:FF:FF	ARP
10:09.865085	60	A	BC:5C:4C:A8:8B:C5	FF:FF:FF:FF:FF:FF	ARP
10:36.375024	60	A	192.168.2.1	224.0.0.1	IGMP
10:36.390122	60	A	192.168.2.100	224.0.0.251	IGMP
10:36.429730	60	A	192.168.2.100	224.0.0.252	IGMP
10:36.430637	60	A	192.168.2.100	239.255.255.250	IGMP
10:36.436274	70	A	192.168.2.103	224.0.0.22	IGMP
10:36.695020	70	A	192.168.2.104	224.0.0.22	IGMP
10:36.814429	70	A	192.168.2.102	224.0.0.22	IGMP

# Chapter 4 PoE (Power over Ethernet) Measurement Function

This function measures power (watt), voltage and current provided from a PSE device (Power Sourcing Equipment) which supports PoE/PoE+ (IEEE802.3af/at) to a PD (Powered Device). It can also distinguish types of power supply and appropriate power range. Select “PoE” from mode the top menu screen to use this function.

## 4.1 Connection

Connect PSE (Power Sourcing Equipment) into the port A and PD (Powered Device) into the port B.

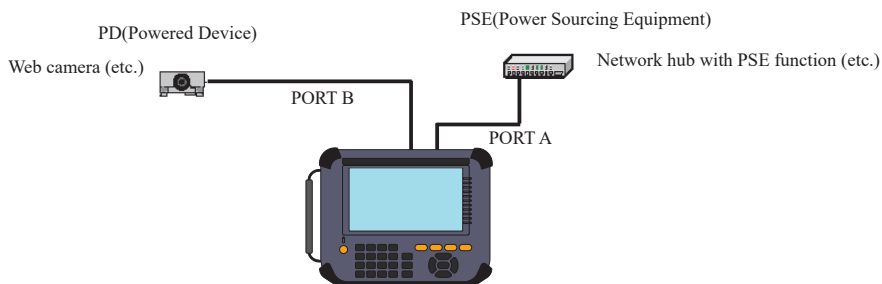

- Cannot measure the PoE line where more than 720mA of current flows for about 3 seconds continuously.

## 4.2 PoE Setup

Press “PoE Opt.” from the PoE mode.

### ■ Specification

Select the PoE specifications (criteria for judging OK/NG on the judgment screen).

The judgment conditions for the selected specification are displayed on the screen.

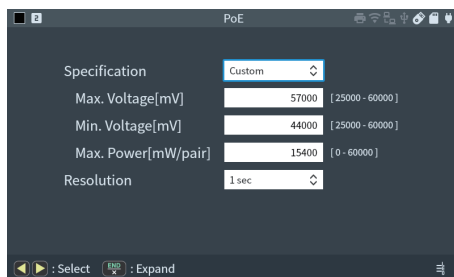

- PoE(PSE) : PoE (PoE+ Type1, PoE++ Type1) judgment on the power supply device side
- PoE+(PSE) : PoE+ Type2, (PoE++ Type2, Type3) judgment on the power supply device side
- PoE++(PSE) : PoE++ Type4 judgment on the power supply device side
- PoE(PD) : PoE (PoE+ Type1, PoE++ Type1) judgment on the power receiving device side
- PoE+(PD) : PoE+ Type2, (PoE++ Type2, Type3) judgment on the power receiving device side
- PoE++(PD) : PoE++ Type4 judgment on the receiving device side
- Custom : Maximum voltage, minimum voltage, maximum power per pair are manually input)

- Resolution  
Select the measurement cycle (interval).

## 4.3 Start and Stop Measurement

Press [RUN] and start measuring. Press [STOP] to finish measurement.

## 4.4 Display

By the buttons displayed at the bottom of the screen, it switches in sequence from “Overview”→“Dump”→“Graph”.

- PoE Overview display

It displays the result of PoE measurement.

Power : Power(W)

Voltage : Voltage(V)

Current : Current(mA)

Min voltage : Minimum voltage (V)

Max voltage : Maximum voltage (V)

Min current : Minimum current (mA)

Max current : Maximum current (mA)

+ pin : The numbers of plus(+) pins.

OK/NG : Judgment result. When it is within the range specified in the PoE settings, OK is displayed.

PoE : 44 to 57V, 15.4W or less

PoE+ : 50-57V, 30W or less

 The judgment result is displayed when the voltage measurement value exceeds 29V.



- PoE dump Display window

It displays the list of recorded data.

Time Stamp : Measured time

Power : Power(W)

Voltage : Voltage(V)

Current : Current(mA)

Timestamp	TypeA Power	Voltage	Current	TypeB Power	Voltage	Current
00,000,002,180	1.8	47.3	39	0.0	0.0	0
00,000,002,190	1.7	47.3	37	0.0	0.0	0
00,000,002,200	1.7	47.3	37	0.0	0.0	0
00,000,002,210	1.7	47.3	37	0.0	0.0	0
00,000,002,220	1.6	47.3	35	0.0	0.0	0
00,000,002,230	1.6	47.3	35	0.0	0.0	0
00,000,002,240	1.6	47.3	35	0.0	0.0	0
00,000,002,250	1.6	47.3	34	0.0	0.0	0
00,000,002,260	1.6	47.3	33	0.0	0.0	0
00,000,002,270	1.6	47.3	33	0.0	0.0	0
00,000,002,280	1.6	47.3	33	0.0	0.0	0
00,000,002,290	1.5	47.3	32	0.0	0.0	0
00,000,002,300	1.5	47.3	31	0.0	0.0	0
00,000,002,310	1.5	47.3	31	0.0	0.0	0
00,000,002,320	1.5	47.3	31	0.0	0.0	0

You can scroll the screen with [▲] [▼] or by swipe.

You can move the position by tapping“Position Jump” and entering the position jump number. Tap“Timestamp” to switch the timestamp display between relative time with the measurement start time as 0 and real-time displayed as hh:mm:ss.msec.

If you tap“A/B Sum” on the PoE Overview display and PoE dump display screen, the current and power values of TypeA and TypeB are added up and displayed.

- PoE graph display

You can switch between show/hide of the graph of the specified data with the check box on the right side of the screen.

Below each check box, the latest data is displayed during measurement, and the numerical value of the data at the cursor position is displayed while measurement is stopped.

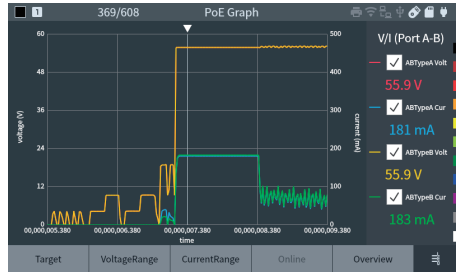

Each time you tap “Target”, the graph display target is switched.

Depending on the graph display target, the range of the vertical axis of the graph changes each time you tap “VoltageRange” “CurrentRange” or “PowerRange” .

Press [SHIFT]+[◀][▶] to scroll at high speed.

- Simultaneous online monitor measurement

During simultaneous measurement with the online monitor, tap “Online” on each screen to return to the LAN frame display screen.

While the measurement is stopped, the display position automatically shifts to the frame closest to the time stamp.

# Chapter 5 Delay time measurement function

Delay Time Measurement Function is a function to measure a time gap between the receiving timings of the ports judging from the send/receive time of LAN communication frames on the network. This function is useful for evaluation of real time Ethernet devices. Select “Delay” from mode on the top menu screen.

## 5.1 Port Selection to Measure

Tap “Delay Opt.” from the Delay time measurement mode and select the ports to measure the time gap. It measures the time gap between the ports specified by “Begin Factor” and “End Factor” .

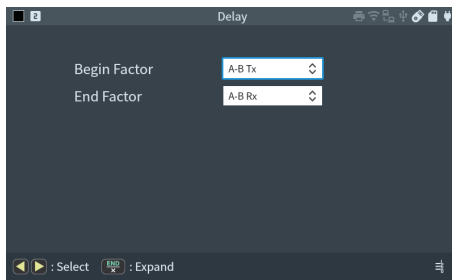

< Setting example1 >

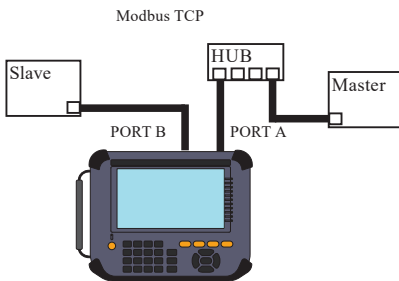

Connect it with a Modbus TCP, configure the layer 2 filter, and set “A-B Tx” to Begin Factor and “A-B Rx” to End Factor. By this setting you can measure the response time of the Slave against the command from the Master.

 A delay occurs by passing through the TAP circuit (between A and C, between C and D) of this device.

The average delay is 1360ns for 1000BASE-T, 1456ns for 100BASE-TX, and 5248ns for 10BASE-T.

The measurement result will be the value obtained by adding this delay time.

< Setting example2 >

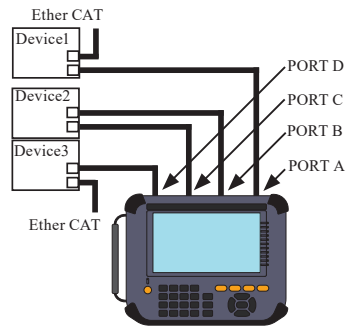

Connect it with an Ether CAT, configure the layer 2 filter, and set “A-B Tx” to Begin Factor and “C-D Tx” to End Factor. By this setting you can measure the processing (response) time of the Device 2 of Ether CAT.

## 5.2 Start and Stop Measurement

---

### Start measurement

Press [RUN] to start the measurement and display the time gap in real time.

- **Count**  
Means how much times measured.
- **Last**  
Means the latest time gap.
- **Minimum**  
Means the minimum time gap.
- **Maximum**  
Means the maximum time gap.
- **Average**  
Means the average of the time gaps during the measurement.

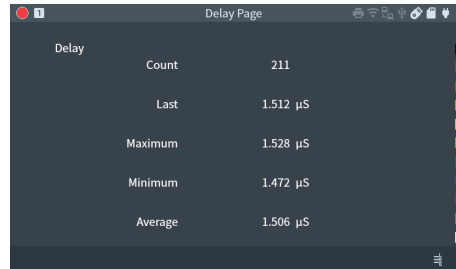

The screenshot shows a mobile application window titled "Delay Page". The window displays a table with the following data:

Delay		
Count		211
Last		1.512 $\mu$ S
Maximum		1.528 $\mu$ S
Minimum		1.472 $\mu$ S
Average		1.506 $\mu$ S

### Stop measurement

Press [STOP] to finish the measurement.

# Chapter 6 Statistic Function

The statistic function is a useful feature to analyze the network traffic and the frequency of the particular frames. To use this function, select “Trend” from mode on the top menu screen.

## 6.1 Connection

Connect the target network to the port A/B/C/D of analyzer.

 3.1 Connection

## 6.2 Frame Counters

Start the measurement. Following frames are counted separately by transmission and reception. Select two kinds of frames for statistical analysis.

Total	: Total number of receiving frames
Good	: Number of normal frames
Broadcast	: Number of broadcasts
Multicast	: Number of multicasts
Pause	: Number of pause frames
0-63(Length1)	: Number of 0 to 63 byte packets
64(Length2)	: Number of 64 byte packets
65-127(Length3)	: Number of 65 to 127 byte packets
128-255(Length4)	: Number of 128 to 255 byte packets
256-511(Length5)	: Number of 256 to 511 byte packets
512-1023(Length6)	: Number of 512 to 1023 byte packets
1024-1518(Length7)	: Number of 1024 to 1518 byte packets
1519-Over(Length8)	: Number of 1519 byte packets and above
CRC error	: Number of CRC errors
Fragment error	: Number of fragment errors*1
Data Rate(1sec.)	: Current data transfer rate (updated every second) *2
Data Rate(Avg)	: Average data transfer rate at the time interval specified on the setting screen

\*1 Frame where an FCS error occurs and its packet length is less than 64 bytes.

\*2 This value cannot be set as a statistical analysis target for graph display.

## 6.3 Statistical analysis settings

Tap “Trend Opt.” from the Statistical analysis function mode.

- Target  
Select the target from transmission line and reception line.  
Tx : Transmission signal  
Rx : Reception signal

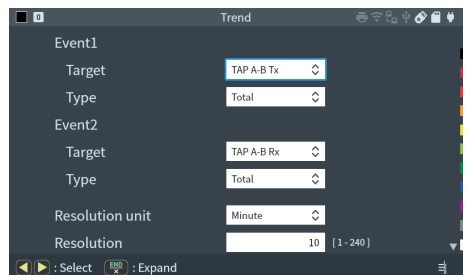

- Type  
Select the target frame counter.
- Resolution unit  
Select the unit of the counting cycle from seconds or minutes.
- Resolution  
When the counting cycle unit is minutes, enter the counting cycle (resolution of the horizontal axis of the statistical graph) in the range of 1 to 240 (minutes), and when it is seconds, enter in the range of 2 to 240 (seconds).

## 6.4 Start and Stop Measurement

- Start measurement  
Press [RUN] to start measuring.
- Stop measurement  
Press [STOP] to stop measuring.  
A measurement is automatically terminated when 100,000 statistics are completed or one of the statistics counters reaches the maximum count of 4,294,967,295.

## 6.5 Display

Each time you tap “Graph” or “Counter”, the display changes.

- Graph display  
Counted values are shown in histogram by unit time of statistics.

“Auto Range ON/OFF” :

Enables/disables the auto range function.

“Range UP” [▲]

“Range Down” [▼] :

When auto range is off, the resolution of the vertical axis of the graph is changed.

After the measurement is completed, you can scroll the screen with [▲][▼] or by swipe.

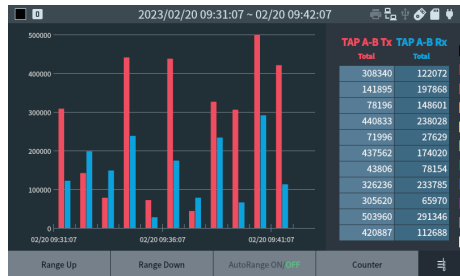

- Counter display  
It shows the total numbers of each counter frame.  
“Data Rate” item displays the data rate.  
Maximum number of counts : 4,294,967,295

	TAP A-B Tx	TAP A-B Rx	TAP C-D Tx	TAP C-D Rx
256-511byte	0	0	0	0
512-1023byte	0	0	0	0
1024-1518byte	325277	0	152530	0
1519byte-Over	0	0	0	0
CRC Error	0	0	0	0
Fragment Error	0	0	0	0
Data Rate(1sec.)	977.305 Mbps	0.00000 Kbps	552.375 Mbps	0.00000 Kbps
Data Rate(Avg.)	614.997 Mbps	0.00000 Kbps	277.739 Mbps	0.00000 Kbps

# Chapter 7 Packet Generator Function

You can transmit any packet by Packet Generator function. To use this function, select [PG] from mode on the top menu screen.

## 7.1 Connection

Connect a target device to test to Port C or D.

## 7.2 Transmission settings

Tap “PG Opt.” from the PG function mode screen to display the PG setting screen.

Set the content and conditions for transmission of packets for Port C and Port D respectively.

- Output Enable

By checking it, packet generation will be performed on that port.

- Edit send table

Edit the contents of the packet to be sent.

- Continuous

When checked, transmission is made continuously.

When not checked, specify the number of times to send.

- Repeat count

When “continuous” mode is not set, it transmits packets for the specified number of times.

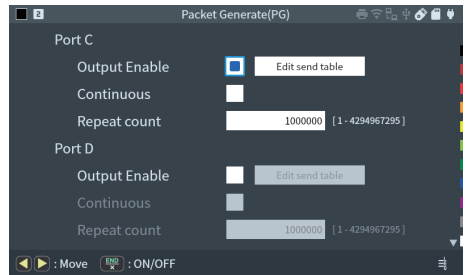

## 7.3 Transmission packet summary

On the PG setting screen, tap “Edit send table” to display a summary of transmission packets.

There are 16 types of transmission tables from No.0 to No.F, and you can enable/disable them individually with the “Select” check box.

No.	Select	Length	Pattern	FrameGap
0	<input checked="" type="checkbox"/>	54	12 34 56 78 9A BC FE DC	128
1	<input type="checkbox"/>	0		128
2	<input type="checkbox"/>	0		128
3	<input type="checkbox"/>	0		128
4	<input type="checkbox"/>	0		128
5	<input type="checkbox"/>	0		128
6	<input type="checkbox"/>	0		128
7	<input type="checkbox"/>	0		128
8	<input type="checkbox"/>	0		128

## 7.4 Editing the transmission packets

You can edit the contents of the table by tapping the table or selecting it with the cursor and pressing Enter or [0]-[F].

- Transmission data input

Set the transmission data.

On the screen, it displays the cursor position in “Pos” and the number of bytes that can be registered in “Remain”.

- 📄 Enter the data in hexadecimal.
- 📄 Packet data can be entered up to a total of 32000 bytes in 16 tables.
- 📄 Enter the data column for the packet that does not contain the FCS.

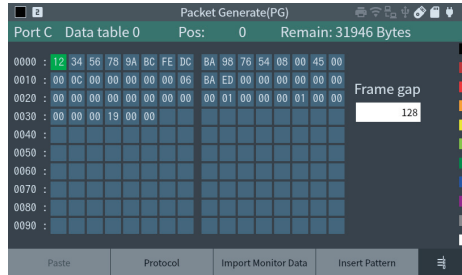

If you long-tap somewhere in the transmission data or press “ENTER”, the range selection mode starts with the data on the location selected. The selection range can be changed by dragging the selection end or [◀][▶]. The length of the selected range is displayed in “Len” on the screen.

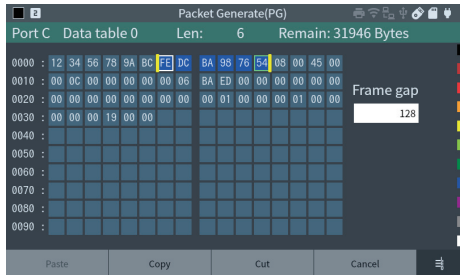

Tap “Paste” “Copy” to save the selection to the clipboard.

Tap [ESC] or “Cancel” to cancel the range selection mode.

Tap “Paste” to insert the contents of the clipboard at the cursor position.

- Frame gap input

Sets the interframe gap (bit). It should be a multiple of 8.

- Protocol Setup

Protocol Setup display shows by pushing “Protocol” at the data table summary display.

Configuration of the selected protocol type (Ethernet, IPv4, ARP, ICMP, TCP, UDP) shows and you can set up a header of the protocol.

According to the protocol and data registration details, it displays the source MAC address, destination MAC address, frame type, etc. By tapping “Apply”, it item overwrites the corresponding data items with the one entered on the protocol edit screen and then returns to the transmission data input screen. Tap “Cancel” or [ESC] to return to the transmission data input screen without changing the data.

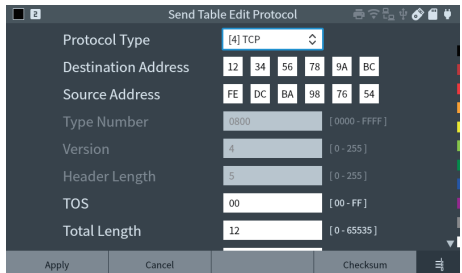

The table below shows the items of the protocols.

To overwrite values of the items, edit the values of the items which you want to change and tap “Apply” .

(For the further details of items of the protocols, refer to standards of the protocols.)

Item	Default Value	Input Value	Remark
<Ethernet>			
Destination MAC address	00-00-00-00-00-00	Hex	
Source MAC address	00-00-00-00-00-00	Hex	
Type	0000	Hex	
<IPv4>			
Destination MAC address	00-00-00-00-00-00	Hex	
Source MAC address	00-00-00-00-00-00	Hex	
Type	0800	Hex	Fixed (cannot overwrite)
Version	4	Decimal	Fixed (cannot overwrite)
Header length	5	Decimal	Fixed (cannot overwrite)
TOS	00	Hex	
Total length	0	Decimal	
ID	0000	Hex	
Flags	0	Decimal	
Fragment offset	0	Decimal	
TTL	0	Decimal	
Protocol	0	Decimal	
Checksum	0000	Hex	*1
Source IP address	0.0.0.0	Decimal	
Destination IP address	0.0.0.0	Decimal	
<ARP>			
Destination MAC address	00-00-00-00-00-00	Hex	
Source MAC address	00-00-00-00-00-00	Hex	
Type	0806	Hex	Fixed (cannot overwrite)
Hardware type	0001	Hex	Fixed (cannot overwrite)
Protocol type	0800	Hex	Fixed (cannot overwrite)
Hardware length	6	Hex	Fixed (cannot overwrite)
Protocol length	4	Decimal	Fixed (cannot overwrite)
Operation code	0000	Hex	
Source MAC Address	00-00-00-00-00-00	Hex	
Source IP address	0.0.0.0	Decimal	
Destination MAC address	00-00-00-00-00-00	Hex	
Destination IP address	0.0.0.0	Decimal	
<ICMP>			
Destination MAC address	00-00-00-00-00-00	Hex	
Source MAC address	00-00-00-00-00-00	Hex	
Type	0800	Hex	Fixed (cannot overwrite)
Version	4	Decimal	Fixed (cannot overwrite)
Header length	5	Decimal	Fixed (cannot overwrite)
TOS	00	Hex	
Total length	0	Decimal	
ID	0000	Hex	
Flags	0	Decimal	
Fragment offset	0	Decimal	
TTL	0	Decimal	
Protocol	1	Hex	Fixed (cannot overwrite)
Checksum	0000	Hex	*1
Source IP address	0.0.0.0	Decimal	

Destination IP address	0.0.0.0	Decimal	
Type	0	Decimal	
Code	0	Decimal	
Checksum	0000	Hex	*1
<TCP>			
Destination MAC address	00-00-00-00-00-00	Hex	
Source MAC address	00-00-00-00-00-00	Hex	
Type	0800	Hex	Fixed (cannot overwrite)
Version	4	Decimal	Fixed (cannot overwrite)
Header length	5	Decimal	Fixed (cannot overwrite)
TOS	00	Hex	
Total length	0	Decimal	
ID	0000	Hex	
Flags	0	Decimal	
Fragment offset	0	Decimal	
TTL	0	Decimal	
Protocol	6	Decimal	Fixed (cannot overwrite)
Checksum	0000	Hex	*1
Source IP address	0.0.0.0	Decimal	
Destination IP address	0.0.0.0	Decimal	
Source port	0	Decimal	
Destination port	0	Decimal	
Sequence number	0	Decimal	
ACK number	0	Decimal	
Data offset	0	Decimal	
Reserved	0	Decimal	
NS	0	Decimal	
CWR	0	Decimal	
ECE	0	Decimal	
URG	0	Decimal	
ACK	0	Decimal	
PSH	0	Decimal	
RST	0	Decimal	
SYN	0	Decimal	
FIN	0	Decimal	
Window	0	Decimal	
Checksum	0000	Hex	*1
Urgent pointer	0	Decimal	
<UDP>			
Destination MAC address	00-00-00-00-00-00	Hex	
Source MAC address	00-00-00-00-00-00	Hex	
Type	0800	Hex	Fixed (cannot overwrite)
Version	4	Decimal	Fixed (cannot overwrite)
Header length	5	Decimal	Fixed (cannot overwrite)
TOS	00	Hex	
Total length	0	Decimal	
ID	0000	Hex	
Flags	0	Decimal	
Fragment offset	0	Decimal	
TTL	0	Decimal	
Protocol	17	Decimal	Fixed (cannot overwrite)
Checksum	0000	Hex	*1
Source IP address	0.0.0.0	Decimal	

Destination IP address	0.0.0.0	Decimal	
Source port	0	Decimal	
Destination port	0	Decimal	
Length	0	Decimal	
Checksum	0000	Hex	*1

**\*1 Checksum calculation**

Checksums of IP frame, ICMP, TCP, UDP can be automatically calculated by tapping “Checksum” .

 If field value (which means length) and number of data of payload and padding do not correspond, calculation will be incorrect.

**■ Importing monitor data**

You can copy the frame contents in the capture memory taken by the online monitor function into the table.

Put data into the capture memory in advance by starting measurement or using the file load function to use this function.

Tap “Import Monitor Data” to display the frame display screen for selecting the frame to import.

The part with the background color at the top of the screen is the frame to be imported. Select data by scrolling the screen and tap “Import” to reflect the packet contents into the transmitted packet table of the PG function.

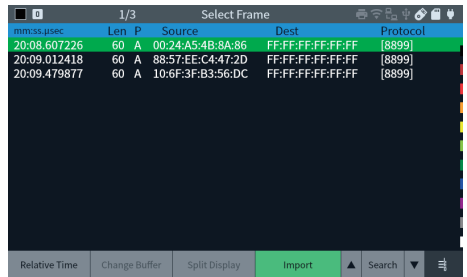

**■ Pattern insertion**

You can register sequential number data of arbitrary length in the transmission data table.

Move the cursor to the position where you want to insert the data, and tap “Insert Pattern”. Select the pattern type and parameters and tap “OK” to insert the data for the specified length.

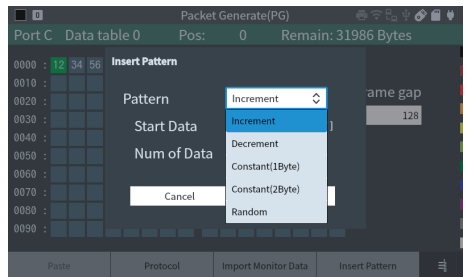

- Increment Inserts ascending sequential numbers (Loops with 0x00 after 0xFF).
- Decrement Inserts descending sequential numbers (Loops with 0xFF after 0x00).
- Constant (1 Byte ) Fills the area with a fixed value.
- Constant (2 Byte ) Inserts two fixed values alternately.
- Random Inserts a random value of between 0x00 and 0xFF.

## 7.5 Start and Stop Testing

When you press [RUN], the “C Port Start” and “D Port Start” parts at the bottom of the screen will be enabled if the link of the transmission port (set one) is established. By tapping here or pressing [C] or [D], the tables set to  (Output Enable) in the send table will be transmitted in sequence.

When the number of transmissions is reached, or when you press [STOP], the transmission ends.

## 7.6 Test Result

The result of packet transmission is displayed on the screen.

<Tx Packet>

Total : Number of transmitted frames

<Rx Packet>

Total : Number of received frames

Good : Number of normal frames

Broadcast : Number of broadcasts

Multicast : Number of multicasts

Pause : Number of pause frames

0-63 : Number of 0 to 63 byte packets

64 : Number of 64 byte packets

65-127 : Number of 65 to 127 byte packets

128-255 : Number of 128 to 255 byte packets

256-511 : Number of 256 to 511 byte packets

512-1023 : Number of 512 to 1023 byte packets

1024-1518 : Number of 1024 to 1518 byte packets

1519-Over : Number of 1519 byte packets and above

CRC error : Number of CRC errors

Fragment error : Number of fragment errors

	C Tx	C Rx	D Tx	D Rx
Total	11148	24	0	0
Good		24		0
Broadcast		7		0
Multicast		17		0
Pause		0		0
0-63Byte		0		0
64Byte		6		0
65-127Byte		14		0

# Chapter 8 Ping Function

You can check the link by making this device join a network and send a Ping command. To use the Ping function, select “Ping” from Mode on the top menu screen.

In Ping mode, PORT C and PORT D of this unit switch from the tap circuit to the normal LAN port and join the network to be tested.

## 8.1 Connection

Connect the LAN port of the target device to PORT C of this unit.

## 8.2 Ping Setup

From the Ping function screen, tap “Ping Opt.” To configure it.

- Destination Address  
Enter the IP address of destination.
- Timeout  
Select the time out limit of Ping response.
- Interval  
Select the interval of repeating the Ping request.
- Data Size  
Enter the data size of ping request packet (ICMP).  
 For the normal testing, it is not necessary to change the default value (64).
- DHCP  
Check if you want to connect to the DHCP server environment and obtain an IP address automatically.
- IP Address  
Enter the IP address of this device.
- Subnet Mask  
Enter the subnet mask.
- Default Gateway  
To communicate over the router, enter the IP address of the router.  
(Enter “0.0.0.0” if unnecessary).
- Tagging  
Select “Enable” to use the VLAN tags.

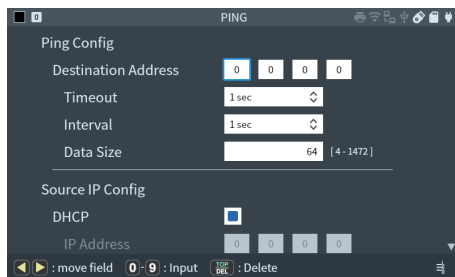

- VLAN ID  
Enter the ID number of the VLAN tag.
- MAC Address  
The MAC address of this device is displayed.

## 8.3 Start and Stop Testing

---

Press [RUN] to start the Ping test.

It sends the ping approximately 30,000 times and the test will end automatically.

If you want to end the test in the middle, press [STOP].

## 8.4 Display

---

During the Ping testing, the situation of test will be described as following.

Send : Number of times transmitted  
 Fail : Number of times failed  
 Current : Latest response time (ms)  
 Minimum : Minimum response time(ms)  
 Maximum : Maximum response time(ms)  
 Average : Average response time (ms)

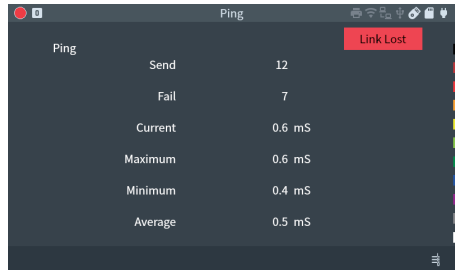

When the Ping commands cannot be transmitted successfully, following message will appear in the upper right of the display.

DHCP Failed: Fail to acquire the IP address from the DHCP server.  
 ARP Failed : Fail to find the Host.  
 Not Link : Fail to link to the network.  
 Link Lost : Fail to link during the transmission.  
 Conflict : When duplicate addresses may exist.

# Chapter 9 Port Blink Function

You can see which port of the hub is connected to the LAN cable by blinking the link LED on the hub connected to PORT C.

To use the port blink function, select “Blink” from the mode on the top menu screen.

## 9.1 Connection

Plug the LAN cable connected to the HUB into the Port C.

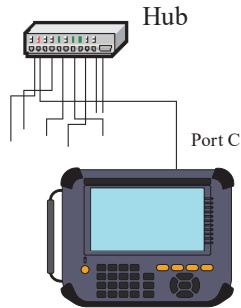

## 9.2 Searching Hub port

Press [RUN] to repeat linking/unlinking from the PORT C to the port of the hub to which PORT C is connected. You can find which port of the HUB is connected to the Port C of OPSB89G by the link LED of the HUB blinking at the same interval.

To stop blinking, press [STOP].

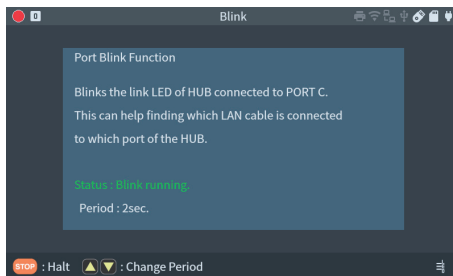

- 📄 The blinking interval could be different by the response time of the HUB. If the response time from the hub is long and it does not blink well, change the blinking interval with the [▲] key.
- 📄 If unplug the cable during the test, blinking may be stopped. In this case, press [STOP] and [RUN] again.

# Chapter 10 Cable diagnostic function

You can measure and diagnose cable length. To use the cable diagnostic function, select “Cable” from Mode on the top menu screen.

## 10.1 How to connect

---

Connect the cable to be measured to PORT C of this device. Do not connect anything to the opposite end of the cable connected to this device.

## 10.2 Setup Cable

---

Tap “Cable Opt.” from the cable diagnostic function mode screen to display the settings screen.

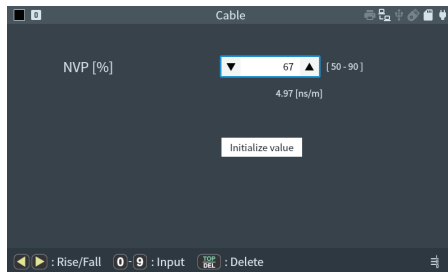

- NVP[%]  
You can change the NVP value (the ratio of the signal propagation speed to the speed of light) in 1% increments depending on the cable.
- Initialize value  
Return the NVP value to the initial value (67%, approximately 5ns/m : General cat.5e cable).

## 10.3 Start and Stop Measurement

---

Press [RUN] and start measuring. Press [STOP] to finish measurement.

## 10.4 Display

---

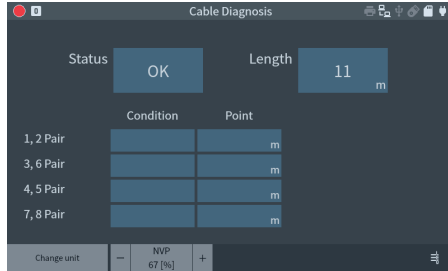

It displays the measurement results for each pair

**Status** : If all measurement results for each pair are normal, “OK” will be displayed.

**Length** : Displays the cable length.

**Condition** : Displays the status (breaking(snapping), short circuit, split pair).

**Point** : Displays the distance of the point where a breaking(snapping), short circuit or split pair was detected.

Each time you tap “Change unit”, the display unit of the cable length and abnormal point will switch between meters (m) and feet (ft).

By tapping “-” or “+”, you can change the NVP value in 1% increments even during measurement.

## 10.5 Adjustment of NVP value

---

If you set the NVP value using a cable of the same type and known length as the cable to be measured, you can measure the cable length more accurately.

Adjustment procedure

1) Connect a cable of the same type and known length as the cable to be measured to PORT C.

We recommend a cable of 10m or more. If the cable is short, the error will be large.

2) Select “Cable” from Mode on the top menu screen and press [RUN].

3) Tap “-” and “+” to adjust the NVP value so that the displayed cable length is the same as the actual length of the cable.

# Chapter 11 Link status information Function

You can read the PHY registers and check the link status information of the equipment connected to each port. To use this function, select “LinkInfo” from Mode on the top menu screen.

## 11.1 How to connect

Connect the measurement target to PORT A, PORT B, PORT C, and PORT D of this device.

## 11.2 Starting and ending measurement

Press [RUN] to start measurement. When you want to end the measurement, press [STOP].

## 11.3 Link status information items

After the PHY exchange link status information, you can check whether each of the following items is valid. If it is valid, it will be Yes, if it is invalid, it will be No.

\* If C-D port is disabled, you cannot check C-D port information.

- AutoNego Available : Auto negotiation available
- BasePage Acknowledge : The basic information page for auto negotiation was received correctly.
- Remote Fault : Auto negotiation pulse cannot be received
- 1000BASE-T Full Duplex : Available
- 1000BASE-T Half Duplex : Available
- 100BASE-TX Full Duplex : Available
- 100BASE-TX Half Duplex : Available
- 10BASE-T Full Duplex : Available
- 10BASE-T Half Duplex : Available
- Pause : Supports symmetrical pause
- Asymmetric Pause : Supports asymmetric pause
- NextPage Available : Supports NextPage
- NextPage Indicate : Use NextPage
- NextPage Receive ACK : NextPage was received

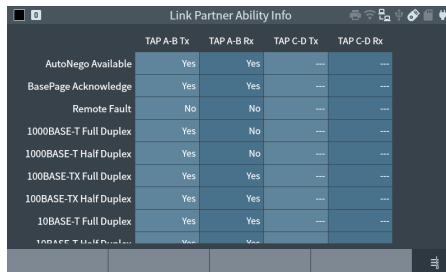

	TAP A-B Tx	TAP A-B Rx	TAP C-D Tx	TAP C-D Rx
AutoNego Available	Yes	Yes	---	---
BasePage Acknowledge	Yes	Yes	---	---
Remote Fault	No	No	---	---
1000BASE-T Full Duplex	Yes	No	---	---
1000BASE-T Half Duplex	Yes	No	---	---
100BASE-TX Full Duplex	Yes	Yes	---	---
100BASE-TX Half Duplex	Yes	Yes	---	---
10BASE-T Full Duplex	Yes	Yes	---	---
10BASE-T Half Duplex	Yes	Yes	---	---

Depending on the auto negotiation setting in the interface settings, the display will be as shown below.

- When auto negotiation is on

The link status is displayed only when TAP is established on A-B port or C-D port.

- When auto negotiation is selected

Regardless of the link status, if the device connected to each port supports auto-negotiation, the exchanged information will be displayed. The information is displayed even if auto-negotiation fails.

If nothing is connected, the previous information will be displayed. If you connect another device again, the contents will be overwritten.

- When auto negotiation is off

The link information cannot be confirmed.

# Chapter 12 Network Emulation Function

You can intentionally generate delays and packet loss in packets passing between the A and B ports of this unit to reproduce a poor network environment and perform operation tests.

## 12.1 Switching the device's operating mode

When using the network emulation function, you must first switch the device's operating mode. To switch from normal mode to network emulation mode, tap “Interface” from the top menu to open the interface settings screen, and tap “switch” in the operating mode settings section.

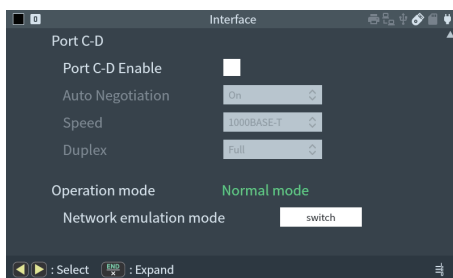

- \* The device needs to be rebooted to switch operating modes, so when you do this a confirmation screen will appear and then the device will shut down.

In the network emulation mode, only online monitor (ONLINE) and statistical analysis (TREND) can be selected as measurement modes. In the network emulation mode, (NE) is added to the end of each measurement mode name on the top menu screen.

To return the unit's operating mode to the normal mode, perform the same operation from “Interface” and reboot the unit.

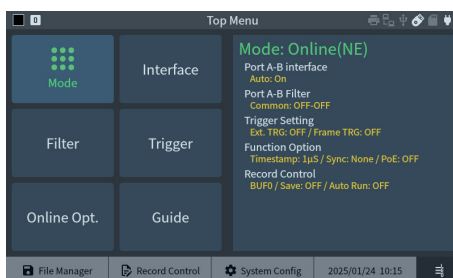

Note: Measurement settings such as filters/triggers are not shared between the normal mode and the network emulation mode, and the configuration files (.SU) are incompatible. Settings must be made within each operating mode.

Data files (.DT) can be loaded mutually only for data in ONLINE measurement mode. For example, you can load data acquired in normal mode into BUF1 and data acquired in network emulation mode into BUF2, and compare the data using the split buffer display.

## 12.2 Connection in Network Emulation Mode

Connect the LAN cable through which data flows between the connected devices to PORT A and PORT B of the unit in the same way as when using the online monitor function/statistical analysis function in normal mode.

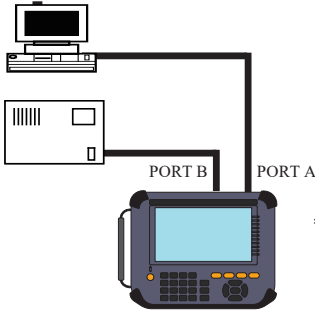

\* In the network emulation mode, PORT C and PORT D are not available.

In the network emulation mode, ports A and B are connected to each other via a software bridge within the unit, not via a hardware TAP circuit as in normal mode.

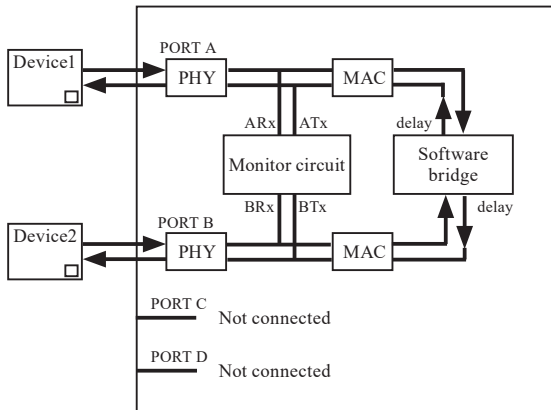

For packets passing between ports A and B, operations such as delay insertion are performed according to the settings when they pass through the software bridge.

The monitor circuit records packets before and after operations such as delay insertion as follows:

PORT A Rx	Packet received from PORT A before operations such as delay insertion are performed
PORT A Tx	Packet received from PORT B after operations such as delay insertion are performed
PORT B Rx	Packet received from PORT B before operations such as delay insertion are performed
PORT B Tx	Packet received from PORT A after operations such as delay insertion are performed

When the analyzer is turned off, the internal wiring switches to a fail-safe state in which the devices are directly connected to each other, just like in normal mode.

[Limitations]

Since the circuit between Ports A and B does not work as a hardware TAP circuit, it has the following restrictions that are different from normal mode.

- The transferable communication data rate is limited by the capabilities of the software bridge. If high-load communication is performed when connected to 1000BASE-T, unintended delays and packet loss may occur.
- The maximum throughput without operations such as delay insertion is approximately 500Mbps.
- Even if the delay time is set to 0, a delay of several tens of microseconds will occur.
- Abnormal frames such as FCS errors and some special frames cannot pass through the software bridge.
- If high-load communication continues when connected to 1000BASE-T, it may interfere with key input and touch panel operation on the main unit. In such cases, unplug the LAN cable from each port after the measurement is completed and then perform the necessary operations.

[Line state indicator LED]

When in network emulation mode, the line state indicator LED will switch to the following:

Link A	A port link-up status
Link B	B port link-up status
A 100M	A port 100BASE-TX *
A 1000M	A port 1000BASE-T *
A Duplex	A port full duplex connection
B 100M	B port 100BASE-TX *
B 1000M	B port 1000BASE-T *
B Duplex	B port full duplex connection

\* When both 1000M and 100M are off, it becomes 10BASE-T.

## 12.3 Network Emulation Settings

Tap “Interface” from the top menu to open the interface settings screen.

When in the network emulation mode, the interface settings screen will be dedicated to this mode, where you can configure the interface settings and the network emulation function.

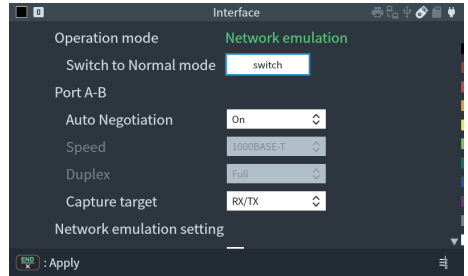

- Operation mode

To return the unit to normal mode, tap “Switch”.

\* Switching operation modes requires the unit to be rebooted, so when you do this, a confirmation screen will appear and then the unit will shut down.

- Auto Negotiation

The meaning of “Off” and “Select” is the same as in normal mode.

3.2 Interface Setup

Only when “On” is selected, the operation differs from normal mode.

In the network emulation mode, PORT A and PORT B of this unit perform auto-negotiation with each device independently. This is to reproduce the situation in an actual environment where each device at both ends of the network performs auto-negotiation with a hub or router. As a result, the link speed may be different.

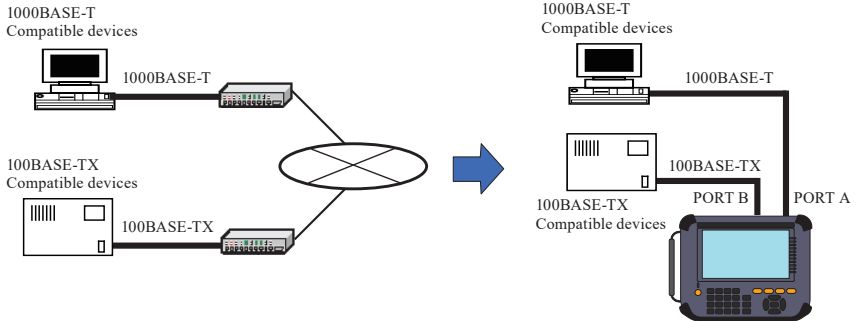

- Capture target

You can limit the lines to be captured when analyzing with external software such as Wireshark.

**RX/TX** : The same packet is captured twice, once before operations such as delay insertion (PORT A Rx/PORT B Rx) and once after operations such as delay insertion (PORT A Tx/PORT B Tx). Since you can observe the actual delay time and packet loss that occurred, this is suitable for using data only with this unit for detailed analysis.

**RX** : Packets are captured before operations such as delay insertion (PORT A Rx/PORT B Rx).

**TX** : Packets are captured after operations such as delay insertion (PORT A Rx/PORT B Rx).

If you select“RX/TX” and convert the acquired data to pcap format and analyze it with Wireshark, the same packet will appear to be sent twice, and the analysis may not be performed correctly.

Example: It will appear as if duplicate ACKs and retransmissions are occurring for all TCP communication packets.

- Network Emulation Settings

Set the emulation operation to be performed on packets passing between Port A and B.

The operation set here will be the initial state that will be reflected when measurement starts.

The emulation operation can be changed even during measurement.

- Enable

When disabled (unchecked), no emulation operation is performed.

The device's software bridge will attempt to forward packets to the opposite port with as little latency as possible, just as when measurement is stopped.

If you check Enable, the following items will be displayed:

- Direction

If you select “Direction”, operations such as delay insertion will be performed regardless of the communication direction. If you

check the amount of delay using ping, etc., the delay observed as a round-trip delay will be approximately twice the set value. If you want to insert an asymmetric delay in only one direction, select “A→B” or “B→A”.

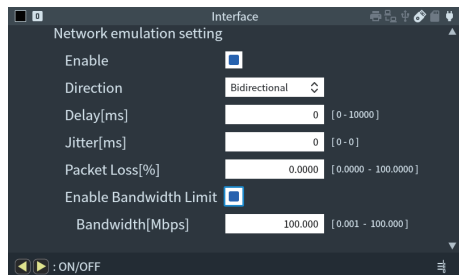

- Delay
 

Enter the amount of fixed delay to be inserted. It can be set in 1 ms increments up to a maximum of 10 seconds (10,000 ms).

\* The maximum number of packets that can be held within this unit's software bridge is 10,000. If you set a delay time that is too long compared to the amount of data that flows steadily, the number of packets received within the delay time may exceed 10,000, resulting in unintended packet loss. Please set the delay time within an appropriate range after checking the number of packets flowing per second using the statistical analysis (TREND) function in advance.
- Jitter
 

Sets the random width for the delay time to be inserted. It can be set in 1 ms increments up to a maximum of 4 seconds (4,000 ms), but it cannot be longer than the time set in "Delay".

\* If the fluctuation width is set to a large value, the transmission order may be swapped.
- Packet Loss
 

Set the probability of intentionally causing packet loss. It can be set in increments of 0.0001% (1ppm) up to 100%.
- Enable Bandwidth Limit
 



Checking this box will display a bandwidth input field, allowing you to add a bandwidth restriction. The bandwidth restriction can be set within the range of 0.001 Mbps (1 kbps) to 100 Mbps.

## 12.4 Other Measurement Settings

---

Other measurement settings and recording control settings are performed in the same way as in the normal mode.

If you use the online monitor (NE) function, please refer to the following.

- Filter settings  3.3 Filter Setup
- Trigger settings  3.8 Trigger Function
- Online monitor settings  3.4 Online monitor Configuration

\* In the filter settings and trigger settings, PORT A Rx and PORT B Tx are treated as PORT A (PORT A-B Tx), and PORT B Rx and PORT A Tx are treated as PORT B (PORT A-B Rx).

If you use the statistical analysis (NE) function, please refer to the following:

- Statistical analysis settings  6.3 Statistical analysis settings

## 12.5 Online Monitor (NE) Function Display Screen

The measurement port name is displayed on the online monitor (NE) function display screen as follows.

Display	Meaning
AR	PORT A Rx
AT	PORT A Tx
BR	PORT B Rx
BT	PORT B Tx

You can also change the network emulation settings during measurement by tapping [SHIFT] + “Change setting”.

The new settings will be reflected immediately when you tap “Apply change”.

Other than that, the screen display and operation methods are the same as when using the normal online monitor function.

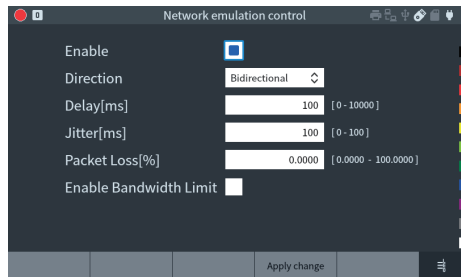
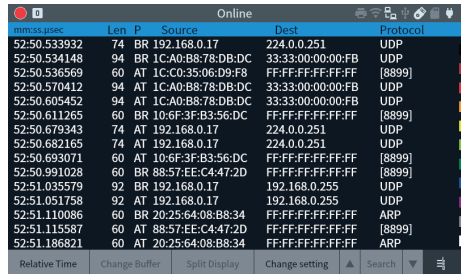

## 12.6 Statistical Analysis (NE) Function Display Screen

	Port A Rx	Port A Tx	Port B Rx	Port B Tx
Total	2	273	274	2
Good	2	273	274	2
Broadcast	1	120	120	1
Multicast	0	149	150	0
Pause	0	0	0	0
0-63byte	0	0	0	0
64byte	1	79	78	1
65-127byte	0	155	156	0

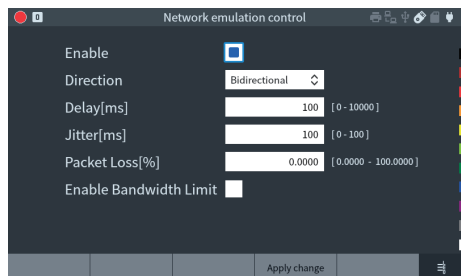

The statistical analysis (NE) function display screen is as follows.

By tapping “Change setting” during measurement, you can change the network emulation settings in the middle of the measurement. The new settings will be reflected immediately when you tap “Apply change”.

# Chapter 13 BERT Function

Performs a BERT (Bit Error Rate Test).

This function uses a test pattern to compare data between the sender and receiver.

## 13.1 Connection Method

---

Connect the ports you want to test of the device under test to PORT C and D.

## 13.2 BERT Settings

---

Tap “BERT Opt” to display the BERT settings screen.

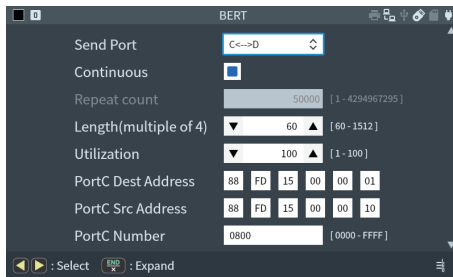

- **Send Port**  
Select the port to send data.  
It sends data in the direction of the arrow.  
By “C <--> D”, it sends from both the C and D ports simultaneously.
- **Continuous**  
Check this box to send continuously.  
If you do not check this box, you can specify the number of times to send.
- **Repeat count**  
If not in continuous mode, the packet will be sent the set number of times.
- **Length(multiple of 4)**  
Set the length of the packet to be used for the test.  
If it is not a multiple of 4, it will be automatically truncated.

- Utilization

Sets the bandwidth utilization rate for sending packets.

When the frame gap is 96 bits (12 bytes), it is considered to be 100%.

The utilization rate is expressed by lengthening the frame gap time as shown in the figure below.

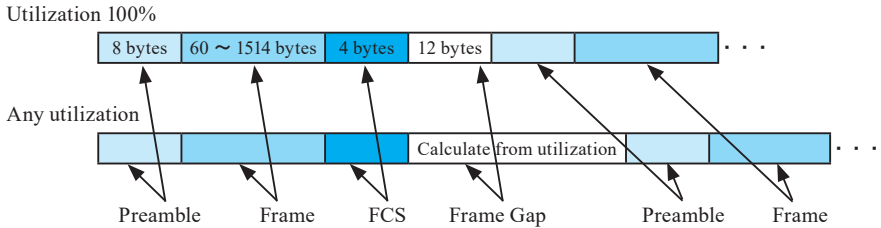

- PortC Dest Address

Sets the destination MAC address of packets sent from port C.

- PortC Src Address

Sets the source MAC address of packets sent from port C.

- PortC Number

Sets the L2 type of packets sent from port C.

- PortD Dest Address

Sets the destination MAC address of packets sent from port D.

- PortD Src Address

Sets the source MAC address of packets sent from port D.

- PortD Number

Sets the L2 type of packets sent from port D.

## 13.3 Start and End of the Test

---

Press [RUN] to start the BERT.

After establishing the link, it will send a learning packet for the MAC address you set and resolve the address of the test target.

Then it will send the test packets the number of times you set and compare the received packets.

It will automatically end when it has sent the set number of times.

In continuous mode, it will continue sending until [STOP] is pressed.

## 13.4 Display Screen

---

Rx Packet	Number of packets received
Tx Packet	Number of packets sent
CRC Error	Number of CRC errors that occurred
Bit Error	Number of bit errors that occurred
CRC Error Rate	CRC error rate
Bit Error Rate	Bit error rate
7bit to 0bit	Number of errors in bits when bit errors occurred

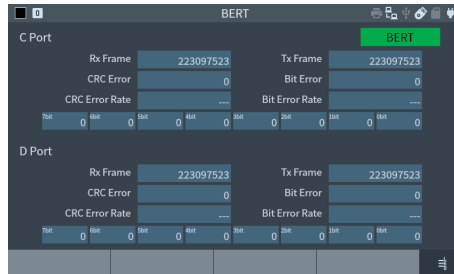

# Chapter 14 RFC2544 Test Function

Performs throughput tests, latency tests, frame loss rate tests, and back-to-back tests in accordance with RFC2544, a performance test for network equipment.

## 14.1 How to connect

Connect the port to be tested of the target device to PORT C and D.

## 14.2 RFC2544 Settings

Tap “RFC2544 Opt” to display the RFC2544 settings screen.

- **Send Port**  
Select the port to send data.
- **PortC Src Address**  
Set the source MAC address of packets sent from port C.
- **PortD Src Address**  
Set the source MAC address of packets sent from port D.
- **Test Frame Size**  
If you check the standard sizes, the frame sizes used in the test will be 64, 128, 256, 512, 1024, 1280, and 1518.  
If you do not check the standard sizes, you can select up to four custom sizes. Only the checked custom sizes will be sent.
- **Throughput**  
Check this to perform a throughput test.  
You can set the transmission time.
- **Latency**  
Check this to perform a latency test.  
You can set the transmission time.
- **Frame Loss Rate**  
Check this to perform a frame loss rate test.  
You can set the transmission time.
- **Back to Back**  
Check this to perform a back-to-back test.

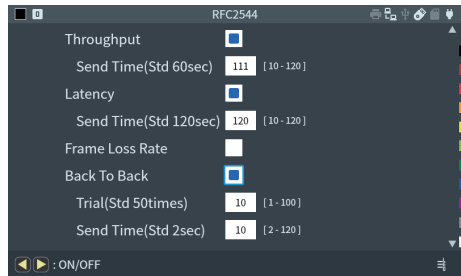
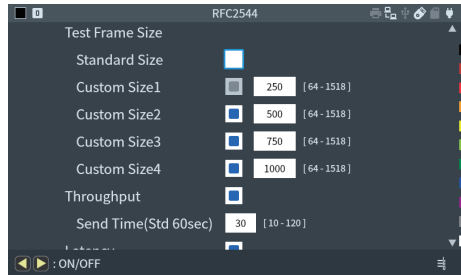
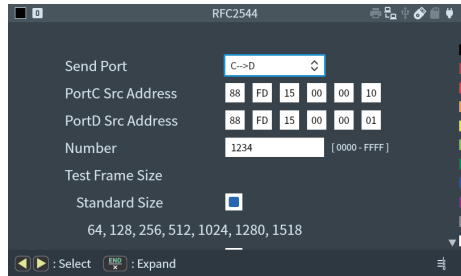

## 14.3 Start and End of the Test

Press [RUN] to start the RFC2544 test.

After the link is established, a learning packet for the configured MAC address will be sent and the address of the test target will be resolved.

Then the tests checked on the settings screen will start.

The test will automatically stop when it is complete.

## 14.4 Display Screen

### ■ Throughput Test Screen

#### • Definition of Throughput in RFC1242

The maximum rate at which frames can be delivered without being dropped by the device.

The throughput test finds the maximum rate by changing the frame bandwidth utilization.

Sends are made for the set time and a comparison is made to see if there are any drops between sender and receiver.

The first time it is sent at 100% utilization. If a drop occurs, the second time it is sent at 80% utilization.

If the second time is successful, it will be sent at 90%, which is between 100% and 80%.

If the second time is unsuccessful, it will be sent at half of 80%, 40%.

If it is successful from the second time onwards, it will be sent at a utilization rate calculated by adding the current utilization rate from the most recent failure and dividing it by two.

If it fails after the second time and has never been successful, it will be sent at half the current utilization rate.

If it has been successful at least once, it will be sent at a utilization rate calculated by adding the current utilization rate from the most recent success and dividing it by two.

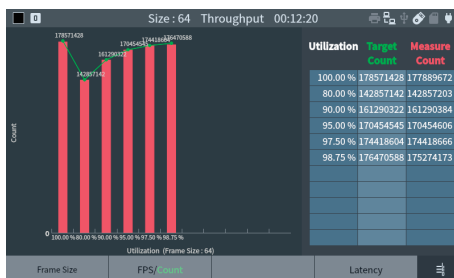

The x coordinate of the graph displays frame size and utilization rate.

The y coordinate displays frame rate or number of packets received. You can switch between these using "FPS/Count" in the footer.

When stopped, "Frame size" in the footer will switch the tested frame size.

When running, the frame size will be updated automatically.

- Latency test screen

- Definition of latency in RFC1242

For store-and-forward devices:

The time interval between when the last bit of an input frame arrives at the input port and when the first bit of an output frame appears at the output port.

For bit-forwarding devices:

The time interval between the end of the first bit of the input frame arriving at the input port and the start of the first bit of the output frame appearing at the output port.

Bit-forwarding devices are also known as cut-through devices.

In a latency test, test packets are sent from the transmitting port for the set time and the latency of each receiving port is measured.

A capture buffer is used to measure latency.

The latency is calculated once 1GB has accumulated.

The screenshot shows a window titled "Latency 00:15:50" with a table of performance metrics. The table has 8 columns: Size, fps, S&F Avg, S&F Min, S&F Max, CT Avg, CT Min, and CT Max. The rows represent different frame sizes: 64, 128, 256, 512, 1024, 1280, and 1518 bytes. The values are in microseconds (uS). At the bottom right, there is a "FrameLossRate" field.

Size	fps	S&F Avg	S&F Min	S&F Max	CT Avg	CT Min	CT Max
64	1488095	4.213 uS	3.850 uS	4.946 uS	4.725 uS	4.362 uS	5.458 uS
128	844594	4.328 uS	4.002 uS	5.090 uS	5.352 uS	5.026 uS	6.114 uS
256	452898	4.153 uS	3.850 uS	4.930 uS	6.201 uS	5.898 uS	6.978 uS
512	234962	4.214 uS	3.930 uS	4.938 uS	8.310 uS	8.026 uS	9.034 uS
1024	119731	4.351 uS	4.002 uS	5.098 uS	12.543 uS	12.194 uS	13.290 uS
1280	96153	4.326 uS	4.114 uS	5.226 uS	14.566 uS	14.354 uS	15.466 uS
1518	81274	4.203 uS	3.826 uS	4.922 uS	16.347 uS	15.970 uS	17.066 uS

Size : Frame size sent

fps : Frame rate

S&F Avg : Store & Forward latency average

S&F Min : Store & Forward latency minimum

S&F Max : Store & Forward latency maximum

CT Avg : Cut-through latency average

CT Min : Cut-through latency minimum

CT Max : Cut-through latency maximum

\* Due to slight discrepancies in the timing of transmission and reception in the internal circuit, there will be an error in the measurement result of about  $\pm 250\text{nS}$ .

If the measurement result is  $300\text{nS}$  or less, the display will show "< 300nS."

- Latency test screen

- Definition of frame loss rate in RFC1242

Percentage of frames that should have been forwarded by a network device under steady state (constant) load that were not forwarded due to lack of resources.

The frame loss rate test calculates the frame loss rate from the number of packets sent from the transmitting port and the number of packets received at the receiving port at the set utilization rate.

If the loss rate is 0%, the test is performed again with the same utilization rate, and if it is 0%, the test is completed there.

If the loss rate is 0% or above, the utilization rate is reduced by 10% and the loss rate is calculated again.



The x coordinate of the graph represents frame size and utilization rate.

The y coordinate represents frame loss rate.

While stopped, the frame size tested will change in “Frame Size” in the footer.

While running, the frame size will be updated automatically.

■ Back-to-back test screen

- Definition of back-to-back in RFC1242

Starting from an idle state, fixed-length frames are transmitted over a short to medium period at a rate that ensures a precise minimum interval between frames.

In a back-to-back test, packets are sent at the maximum rate for the number of seconds and times you set.

The frame/s is calculated for each test. The average, minimum, maximum, and standard deviation are displayed.

Size	Count	Average FPS	Minimum FPS	Maximum FPS	std Deviation
64	30	1488095	1488095	1488095	0.000
128	30	844595	844595	844595	0.000
256	30	452899	452899	452899	0.000
512	30	234962	234962	234963	0.305
1024	30	119732	119732	119732	0.000
1280	30	96154	96154	96154	0.000
1518	30	81274	81274	81275	0.305

Size: Frame size sent

Count: Number of times sent

Average FPS: Average frame rate of the test results

Minimum FPS: Minimum frame rate of the test results

Maximum FPS: Maximum frame rate of the test results

std deviation: Standard deviation of the test results

# Chapter 15 Save and Load of the Data

## 15.1 Storage device

An SD/SDHC card or USB flash drive can be used as a storage device, and measurement data and setting data can be saved to it.

- Optional SDHC cards (SD-8GX, SD-16GX, SD-32GX, sold by LINEEYE) are available. You can use a USB flash drive, but we do not guarantee the operation of all USB flash drives.
- Storage devices formatted with exFAT or NTFS cannot be used. You need to reformat it with FAT32 before use, but it may not be possible on Windows depending on the version and capacity. Use the tools provided by each storage device manufacturer.

The measurement data automatically saved in the storage device using the auto save function etc. is saved in the storage device specified in “Save Device” of the auto save tab of “Record Control” in [MENU].

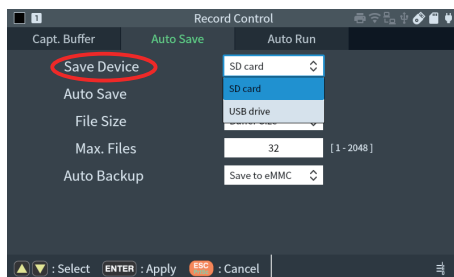

If you select either “USB drive” or “SD card” for “Screen shot save to” in the Display/Power tab of “System Config” in [MENU], the screenshot will be saved in the external storage device.

When both storage devices are connected, it will be saved to the storage device specified in this setting.

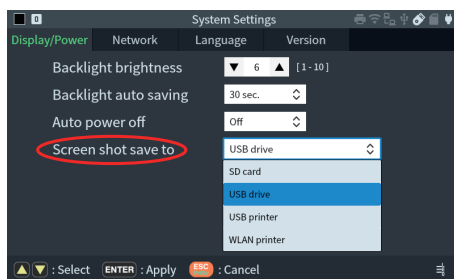

## 15.2 File Management Function

You can save, read, and delete the measured data and setting data in the storage device as a file that can be read/written by a PC.

Tap File Manager on the top menu screen to move to the connected storage directory screen or printer management screen.

Tap “File Manager” or “Device Change” at the bottom of each screen to switch to each screen.

File management operations are performed on the directory screen.

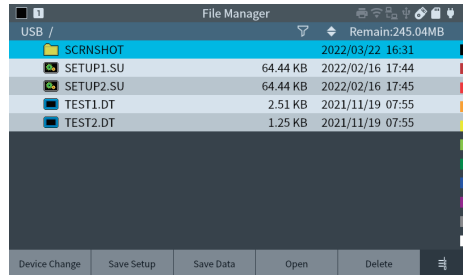
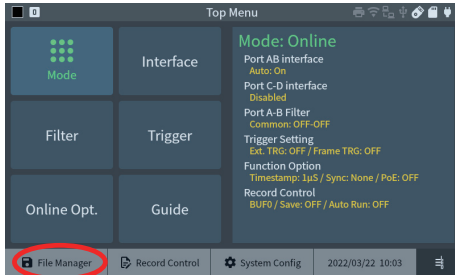

You can scroll and display the files on the directory screen by swiping the screen or by pressing [▼] or [▲]. If both the SD/SDHC card and the USB memory are inserted, tap “Device Change” at the bottom of the screen to switch to the directory screen of the storage device to be operated.

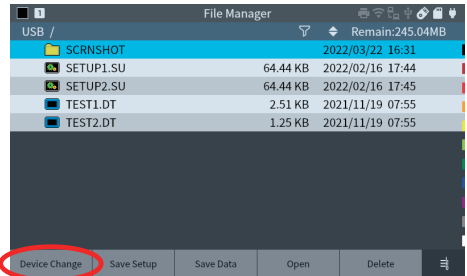
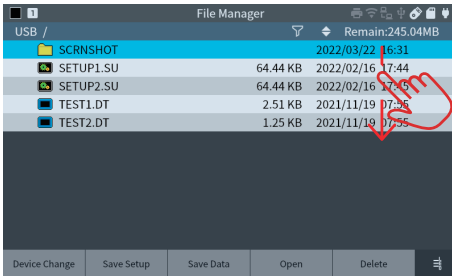



### Save data

When you tap “Save data” on the directory screen, the full key image and text input window will be displayed on the screen.

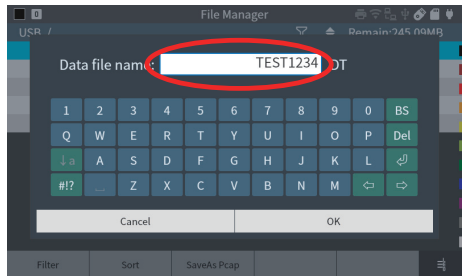
Touch the keyboard or the full key on the screen to enter the file name and tap “OK” or press [ENTER] to save all measurement data in the capture memory and return to the directory screen. The measurement data file extension DT is automatically added.



-  The file name can be specified with up to 8 characters. You cannot enter lowercase letters.
-  Tap “#!?” to enter a symbol that can be used as a file name.

- ◆ Export Data

If you tap [SHIFT]+“Export” on the directory screen, the file export dialog will be displayed. The item to be selected differ depending on the measurement data.

- Export Type

Select the file output format.

pcapng : Outputs ONLINE monitor measurement data in a format that can be opened in Wireshark.

csv : Output PoE and TREND measurement data in csv format.

txt : Output ONLINE, PoE, TREND measurement data in txt format.

- When the measurement data is“ONLINE monitor” and the output format is txt

- Data Type

From the current position, it transforms the frame display screen by selecting “List” and transforms the detail display screen by selecting “Detail”.

- Number of Pages

Select how many pages to convert from the current position when the data type is List. (15 lines per one page.)

- Number of Lines

Select how many rows of frames to convert from the current position when the data type is Detail.

- When the measurement data is PoE

- Current Position / Total Data

Displays the top data position currently displayed on the PoE dump screen and the total number of captured data.

- Start Position

Enter the position to start converting PoE data.

The initial value is the current display position.

- Number of Convert Lines

Enter the number of lines to convert from the starting position.

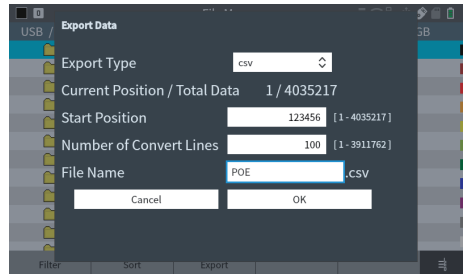

- When the measurement data is ONLINE and PoE simultaneous measurement and the output format is txt

- Export Data

Select the measurement data to output.

The subsequent selection items are the selections for each of the above measurement data.

- When the measurement data is TREND

- Data Type



Select whether the output format is counter or graph.

- Top Position  
Displays the top position of the current graph screen.
- Resolution  
Displays the resolution of the measurement data.
- Number of Data  
Select how many to output from the current top position.
- File Name  
Enter a file name. When selected, a file name input dialog is displayed.  
Tap “OK” or press [ENTER] to save the file to your storage device.

## Save setup

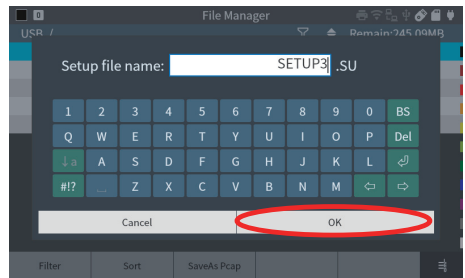
When you touch “Save setup” on the directory screen, the full key image and the text input window will be displayed on the screen. Touch the full key on the screen to enter the file name, and then touch “OK” or press [ENTER] to save all setting data of the top menu and return to the directory screen. The file extension SU of the setting data is automatically added.



-  You can enter the symbols that can be used as the file name by tapping “#!?”.
-  The “System settings” display and Power and network settings are not saved in the setting data file.
-  The “System Settings” display, power setting, and network setting are not saved in the settings data file.



Never remove the storage device while it is accessing files.

## File sorting and display filters

### ◆ Sort

Touch “◆” on the directory screen and specify the file name, extension, size, or modification date to display them in ascending or descending order.

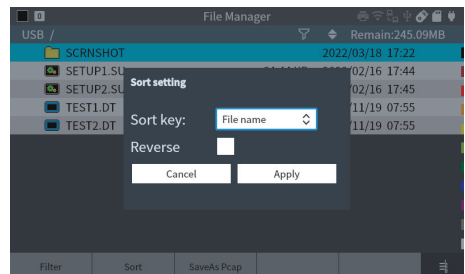
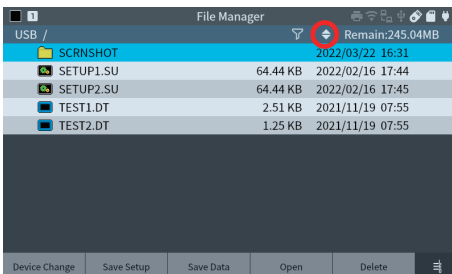

-  The sort display is maintained until you specify it again with “◆” or reboot the device.

## ◆ Filter

Tap “” on the directory screen to display only the specified file type.

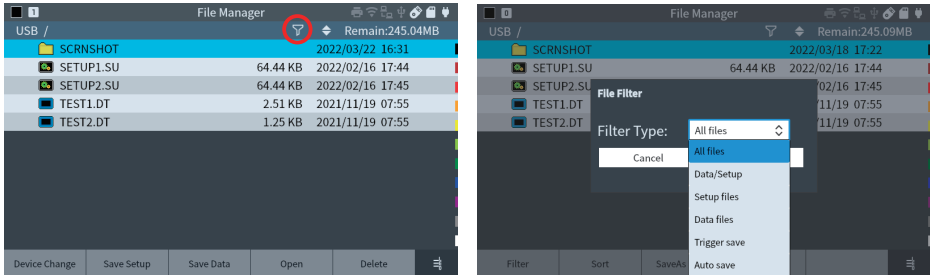

The following file types can be specified for the filter display.

All files

Analyzer measurement data file and setting data file

Analyzer setting data file

Analyzer measurement data file

File automatically saved by the trigger function (TGSAVEnn.DT)

File automatically saved by the auto save function (#nnnnnnn.DT)

When you “Apply” the filter, only the files with the specified conditions will be displayed.

The filter icon turns red while the filter is being applied.

 The filter display will be canceled when you move to another screen.

## Load file

On the directory screen, double-tap the file, or tap the file you want to load or select the file with [▼] or [▲] and then tap “Load File” to load the data of the file. When the setting data file is read, the measurement conditions are uploaded and the menu screen is displayed. When the measurement data file is read, the original measurement data is cleared and the data display screen of the measurement data read from the file is displayed.

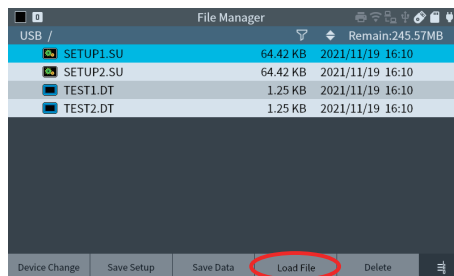



 Files with extensions other than DT, SU, and PNG cannot be loaded.

◆ Loading the file in subdirectory

On the directory screen, double-tap the subdirectory that contains the file you want to read (hereinafter, the folder), or tap it or select it with [▼] or [▲] and then tap “Open” to display the files in that folder. Select the file and execute the load operation.

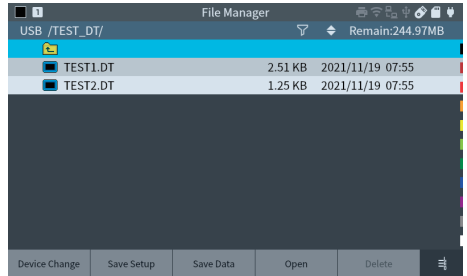
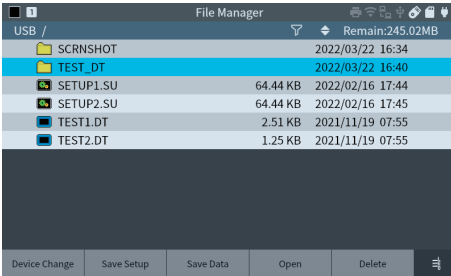
Select “” and touch “Open” to move to the upper directory.



 You cannot create folders or move files to folders on the analyzer. This kind of operation needs to be performed on a PC.

## Delete a file

◆ Delete a file

Tap the file to be deleted on the directory screen or select it with [▼] or [▲], tap “Delete”, and tap “Yes” (or [ENTER]) in the deletion confirmation window to delete the file.

To stop the deletion tap “No”.

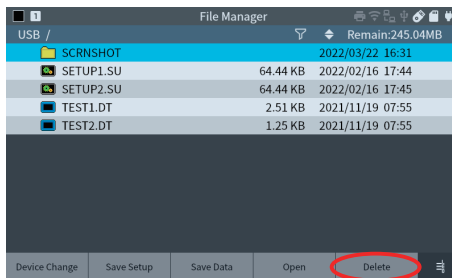

◆ Batch deletion of multiple files

To delete multiple files at once, long-tap (touch for about 1 second) any file on the directory screen to display the file selection display.

Tap the file you want to delete (or select it with [▼] or [▲] and press [ENTER]), and a checkmark will be added to the file. To deselect it tap the selected file again. Tap “Delete” and then tap “Yes” (or [ENTER]) in the deletion confirmation window to delete the selected file.

To cancel the deletion, tap “No”.

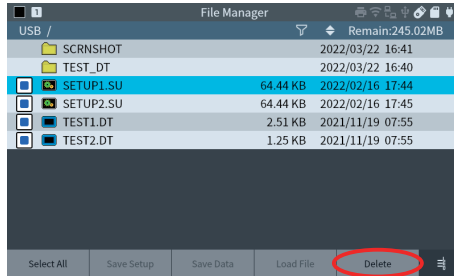

◆ Delete all the files

In the file selection display, tap “Select all” to select all the files displayed in the directory screen. Tap “Delete” and then “Yes” in the confirmation window to delete all the files. When you want to delete all the specified files, for example, only the files automatically saved by the auto save function (#nnnnnnn.DT), you can do so by using the filter display of the files.

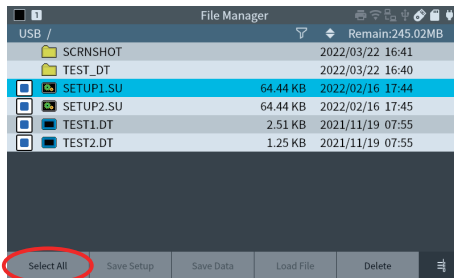

📄 Long tap again or press [ESC] to return to the original display and cancel the selection.

## Error message

---

If an error message is displayed when accessing the storage device, take appropriate action.

When the data could not be read, the following cases can be considered - the storage device is not recognizable, the capture buffer is write-protected, the data is corrupted, or the data was saved with an optional board other than the one currently in use.

When the data could not be saved, the following cases can be considered - the storage device is not recognized, there is no free space in the saving destination, or the saving destination is write-protected.

# Chapter 16 Utility

## 16.1 Key Emulation Software

You can remotely control the analyzer from your PC via USB, LAN or Wi-Fi (supported model only) displaying the analyzer screen.



- Preparation
  1. Execute setup.exe in the lepckeyemu folder in the attached CD to install the software.
  2. From the Start menu, select LINEEYE → LE-PCKEYEMU to start it.
  3. Open the remote settings dialog on the toolbar and specify the LE-8500X series to connect to.

When you operate the analyzer connected via USB, enter the serial number of it (written on the back of the main unit).

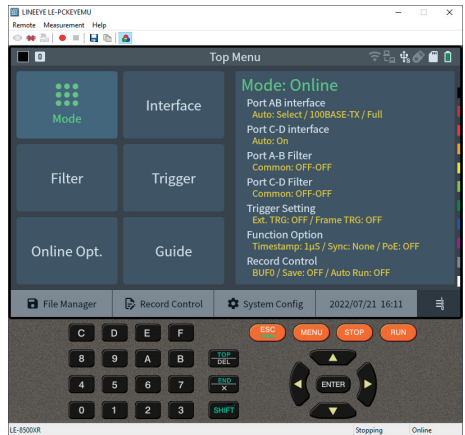
When connected via LAN or Wi-Fi (supported model only), specify the IP address and port number set (or obtained by DHCP) to this unit.



### 2.2.3 System Config Network

- Usage
  1. Start the connection with  in the toolbar.
  2. In addition to the keys, touch operation is also possible by operating the screen part with the mouse.
  3. To finish it, disconnect with  in the toolbar.

For details on how to use it, go to “Help” “Contents” in the drop-down menu to display online help.

-  While the analyzer is remotely connected you cannot control the analyzer physically by the buttons or touch panel. Please disconnect the remote connection for the operation.

## 16.2 Data Conversion Software

The attached CD includes the utility software that converts the communication data captured by this analyzer into a format that can be handled by Wireshark .

In addition to converting DT files in a PC (moved from the analyzer by using external storage), it can start/stop of online monitoring and import of data from the memory of analyzer by connecting it with the PC via USB, LAN, or Wi-Fi (supported model only).

### ■ Preparation

1. Copy lepcapcvt.exe from the lepcapcvt folder in the attached CD to a suitable folder on your computer.
2. Start the software and select the format to convert to from “pcap” and “pcap-ng”. (By the pcap format, the time stamp accuracy that can be handled is 1  $\mu$ second. If you want to handle more accurate time stamps, select pcap-ng.)

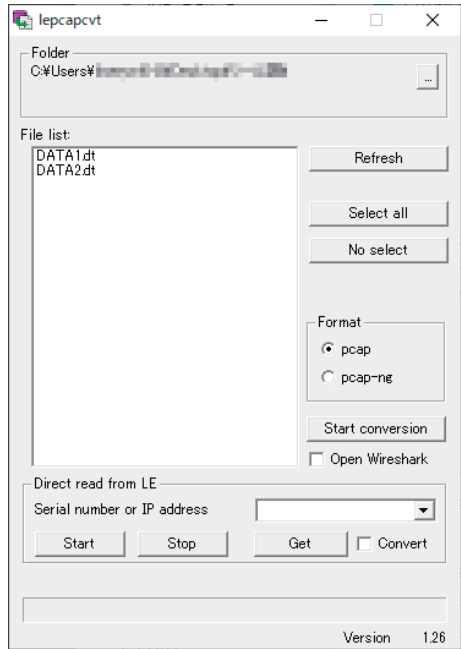

### ■ Conversion of DT files moved to PC via external storage

1. Connect the external storage that has the DT file (measurement data) to the PC, and specify the folder with “Folder”.
2. Select the file to be converted with “File list” and press “Start conversion” to convert.
3. A file with the extension pcap or pcapng with the file name (same name of the unconverted file) will be created in the same folder. If there is already a pcap/pcapng file with the same name, it will be overwritten.
4. If you want to see the contents immediately after conversion, check “Open Wireshark” to open the file with Wireshark.

■ Start/stop of remote measurement and data acquisition

1. Specify the target analyzer in “Serial number or IP address”.

When you operate the analyzer connected via USB, enter the serial number of it (written on the back of the main unit).

When connected via LAN or Wi-Fi (supported model only), specify the IP address of it.

If you have changed the port number of analyzer, input“: port number” after the IP address. (Example“192.168.4.1:10102”)

2. Press “Start” to switch to online monitor mode and start measurement. Settings cannot be configured in this function, thus set them in advance on the analyzer side.
3. Press “Stop” to stop the measurement.
4. Press “Get” to import the monitor data in the memory of the analyzer to the PC. When the import is completed, specify the file name and save it.
5. If you have checked “Convert”, the imported file will be converted immediately. If you also check “Open Wireshark”, the file will be opened with Wireshark as it is.

For details on how to use the software, see readme.txt included in the CD-ROM attached to the product.

-  In order to use the Open Wireshark function, Wireshark must be installed on your PC in advance.

## 16.3 Capture data files while measuring



### “LE file downloader”

“LE file downloader” captures the communication log files saved in the storage device using the auto save function and send them to the PC via LAN or Wi-Fi. This tool is useful to capture the communication log files which has the time stamp around the time when a communication failure occurred, and to analyze the target data using the Wireshark.



“LE file downloader” transfers only the measurement data files with the name of “#nnnnnnn.DT” (n is a sequential number starting from “0”) saved by the auto save function.



### How to use

1. Download and unzip the “LE file downloader (lefiledownload.exe)” of ver.1.04 or later from LINEEYE website to an appropriate folder on the PC. No installation required.
2. Make sure that the analyzer and PC are connected LAN or Wi-Fi.



#### 2.2.3 System Config Network

3. Execute the auto save function.
4. Double-click the “lefiledownload.exe” and enter the IP address and port number of the analyzer, and click “Connect”.
5. The communication log files saved by the auto save function are listed on the window. Click “Update list” to display the latest list.



#### 2.2.2 Record Control Auto Save Function

6. Click [  ] to specify the saving destination, and select the communication log file to be imported to the PC referring to the time stamp of the file.



The communication log file in saving process by the auto save function cannot be downloaded.

7. Click “Download” to start transferring to the specified save destination via LAN or Wi-Fi. It may take 1 minutes or more to transfer a 16Mbyte file, depending on the load of the analyzer and the radio wave condition.
8. Convert the downloaded communication log files using the” Pcap conversion software (lepcapvnt)” of v1.28 or later. It is possible to analyze data using the free software, such as the Wireshark.

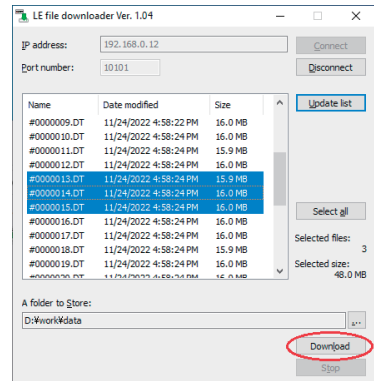
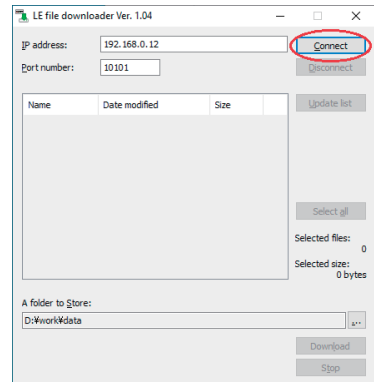

## 16.4 PC Remote Control Library

---

---

The libraries for Windows are available to make a user application software which remotely controls the analyzer from a PC. The library can be downloaded from LINEEYE website.

- For Windows

Windows 11/10/8.1, VC++6.0 and VC++.NET are supported.

Above operating environment is confirmed by our environment and we do not guarantee a correct operation.

# Chapter 17 Printout Function

Measurement data can be printed out on a printer.

You can also print a hard copy, which outputs the image displayed on the screen to the printer as it is. Tap “File Manager” at the bottom of the top menu screen to move to the “File Manager” that displays the directory list of the connected storage or the “Printer Management” that configures printout settings.

Every time you tap “Device Change” or “File Manager” at the bottom of each screen, it switches between “File Manager” of the connected storage and “Printer Management”.

## 17.1 How to Connect to a Printer

Connection with the dedicated printer SM4-31W (option) is via USB or wireless LAN.

- When using the printer via USB

Connect the USB port of this analyzer and the printer with a USB cable.

You can check the status of the USB connection by checking the status of the USB connection on the “Printer Management”.

- When using the printer via wireless LAN

Connect this machine and printer to the same access point, etc., or set the printer's Wi-Fi setting to the Direct mode to connect this analyzer.

Set the IP address and port number set for the printer on the “Printer Management”.

For the printer's Wi-Fi settings, refer to the printer's manual, etc.

## 17.2 Hard Copy of Screen Display

Select USB printer or WLAN printer for Screenshot save to in Display/Power tab of System Config. Press [SHIFT]+[ESC] on the screen you want to output and then the printing will start.

Hard copy print example

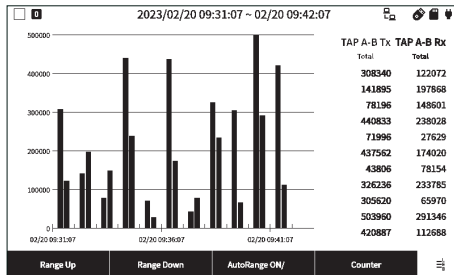

## 17.3 Printout of Measurement Data

When you press “Print” on the printer management screen, a dialog will appear.

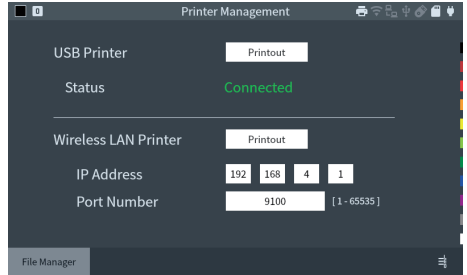

Specify Number of Pages, Number of Lines, etc. in the dialog that appears and press OK. Then the printing will start.

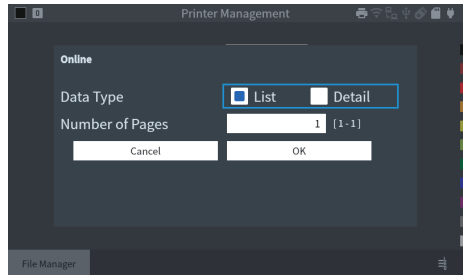

The options in the dialog are the same as those described in the section on Export Data in 10.2 File Management Function.

However, the maximum output is limited to approximately 300 lines for data part.

\* Only measurement data that supports text output can be printed.

### Printing Example of Data

#### ◆ List Data

```

*=[LE-8500X]=== [2023-03-06 15:36:50]=*
* Model : LE-8500X *
* Version : 1.05.05 *
* Extension : SB-GE2 *
* Serial No. : 99999999 *
* Start time : 2023-03-06 15:35:50 *
* Stop time : 2023-03-06 15:36:29 *
*-----*
* PROTOCOL: LAN *
*-----*

-----Time---Len-P---Source-----Destination---Protocol
35:52.671588 66 B 192.168.0.14 192.168.0.47 TCP
35:52.671991 66 A 192.168.0.47 192.168.0.14 TCP
35:52.672159 60 B 192.168.0.14 192.168.0.47 TCP
35:52.675590 584 A 192.168.0.47 192.168.0.14 TCP
35:52.716897 60 B 192.168.0.14 192.168.0.47 TCP
35:52.749521 60 B 192.168.0.14 192.168.0.47 TCP
35:52.749553 60 A 192.168.0.47 192.168.0.14 TCP
35:53.213522 1478 B 192.168.0.14 192.168.0.47 TCP
35:53.213602 60 A 192.168.0.47 192.168.0.14 TCP
35:53.215931 134 B 192.168.0.14 192.168.0.47 TCP
35:53.215960 60 A 192.168.0.47 192.168.0.14 TCP
35:53.235903 710 A 192.168.0.47 192.168.0.14 TCP
35:53.305719 70 B 192.168.0.14 192.168.0.47 TCP
35:53.305790 60 A 192.168.0.47 192.168.0.14 TCP
36:23.920244 118 B 192.168.0.14 192.168.0.47 TCP
    
```

#### ◆ Detail Data

```

*=[LE-8500X]=== [2023-03-06 15:36:57]=*
* Model : LE-8500X *
* Version : 1.05.05 *
* Extension : SB-GE2 *
* Serial No. : 99999999 *
* Start time : 2023-03-06 15:35:50 *
* Stop time : 2023-03-06 15:36:29 *
*-----*
* PROTOCOL: LAN *
*-----*

-----Time---Len-P---Source-----Destination---Protocol
35:52.671588 66 B 192.168.0.14 192.168.0.47 TCP
Ethernet II
Destination: 88-FD-15-02-CC-F0
Source: 00-3F-05-A4-10-54
Type: IP (0x0800)
FCs: 86 3f 07 76
Internet Protocol
Version: 4
Header length: 20
Service type: 0x00
Total length: 52
Identification: 0xCf3D (53053)
Flags: 0x02
Fragment offset: 0
Time to live: 128
Protocol: TCP (0x06)
Header checksum: 0xA9F8 - correct
Source: 192.168.0.14
Destination: 192.168.0.47
Transmission Control Protocol
Source port: 1366
Destination port: ssh (22)
Sequence number: 185437364
Acknowledgment number: 0
Data offset: 32
Flags: ---S- (0x02)
Window: 64240
Checksum: 0xB395 - correct
    
```

# Chapter 18 Specifications and Maintenance

## 18.1 Specifications of Function and Hardware

Interface	RJ-45 connector. Port A/ B/ C/ D: 10BASE-T/100BASE-TX/1000BASE-T Between port A&B is the fail-safe tap. *1
Capture memory	Capacity: 1G byte (96 ~ 10,560 byte for 1 frame, 64 byte for 1 PoE data)
On-line Monitor Function	Record LAN frames between port A&B and port C&D simultaneously, and display them.
Frame Size	60byte ~ 9K byte
Capture performance	About 4Gbps*2
Time stamp	Receiving time is added as time stamp for each received frame. Resolution : 8ns/1us/10us selectable
Data display/operation	2-split comparison display. Able to scroll, search and mark data.
Display	Translatable protocol: IPv4, ARP, ICMP, TCP, UDP, DHCP, Ether CAT, IPv6, ICMPv6
pcap conversion	Measured data can be converted and saved as the pcapng format file.
csv conversion	Measured PoE data can be converted and saved as the csv format file.
Filter Function	Monitor only the specific frames that match one or two specified conditions.
Trigger Function	Factor: Receiving specific frame. Changing the status of external TTL signal. Action: Stop monitoring. Count number of matched times. Output external TTL signal.
Search Function	Search and display the specific frames that match the specific conditions, or counts the number of matched data.
Delay time Function	Measure the time difference of receiving specific frames between port A&B or port C&D. Display the results in max/ min/average/current value.
Statistic Function	It takes statistics of two frame counter values at specified intervals(2 to 240 seconds, 1 to 240 minutes) and can display the graph display,all frame counter values, and data rate in real-time.
PoE Measurement Function	Measure PoE/PoE+/PoE++(IEEE802.3af/at/bt) and LAN frame simultaneously. Recording interval: 1ms ~ 1 s, Max. recording time: 16.77 million times, Voltage : 0 ~ 60V ( accuracy: ± 1% F.S.), Current : 0 ~ ± 900mA (accuracy: ± 1% F.S.) *3
PG Function	Transmit arbitrary packets at the wire rate from port C or D. Up to 16 data tables (total 32K data) can be transmitted sequentially from each port.
Ping Function	Transmit a PING command from port C and display the number of responses and response time (max/ min/average/ current value).
Port Blink Function	Blink the link LED of the Hub to find the LAN cable connected to the port C.
Cable diagnostic function	Measures the cable length (3 to 100m), breaking/short circuit, split pair detection.*7 Method of calculation of length: TDR Margin of error: ±2m *8 NVP value configurable
Link status information function	Auto-negotiation information connected to PORT A, B, C, D can be displayed and link information can be confirmed.
Network Emulation Function	Records frames flowing between ports A and B while inserting delays and packet loss, monitoring and display it in real time, displays statistical analysis. Fixed delay: 1ms to 10 seconds. Random delay: 1ms to 4 seconds. Packet loss: 1ppm to 100%. Bandwidth limit: 1kbps to 100Mbps. Maximum throughput: approx. 500Mbps (at minimum delay).

BERT Function	Bit Error Rate Test allows you to analyze whether bit errors are occurring
RFC2544 Function	Processing capacity can be analyzed using RFC2544-compliant throughput tests, latency tests, frame loss rate tests, and back-to-back tests
Auto save Function	Monitored data is automatically saved as a log file in the USB memory/SDHC while it keeps monitoring. <sup>*4</sup>
Useful Function	Time synchronized function from PPS signal or external PPS signal of GNSS. Auto back-up function. Auto RUN/STOP function. Power on run function
LCD display	7 inch TFT color display (480x272dot) with capacitive touch panel
Line Status LED	11 LEDs. Indicate the linking status of port A, B, C, D. Indicate the speed (100BASE/TX, 1000BASE-T) and full-duplex for port A&B and C&D.
LAN Port	RJ45 connector for PC connection. 1000BASE-T Ethernet: IEEE 802.3
USB device port	Type-C connector for PC connection. Super Speed supported.
USB host port	Standard A connector for USB memory. Super Speed supported.
SD card slot	For standard size of SD/SDHC memory card. Compliant with SD association standard.
External I/O terminal	4-pin for trigger function
GPS Antenna Connector	SMA( female ) connector
PPS Signal Connector	SMA( female ) connector
Wi-Fi interface <sup>*5</sup>	IEEE802.11b/g/n. Frequency range: 2412MHz ~ 2484 MHz <ul style="list-style-type: none"> <li>• Transmission power 802.11b: +18.5dBm 802.11g: +18.0dBm</li> <li>802.11n: +17.0dBm</li> </ul>
Printout function	Measurement data can be output to printer. Screen image can be output to printer.
Power	Attached AC adapter. Lithium-ion rechargeable battery (model : P-26LW2) Battery drive time: 2 hours <sup>*6</sup>
Temperature	In operation : 0 ~ 40°C In storage : -20 ~ 50°C
Humidity	20 ~ 85%RH (no condensation)
Standard	CE ( class A )
Dimensions (W×D×H) , Weight	234(W)×186(D)×44(H) mm, Approx. 990g

- \* 1 When the power of analyzer is turned off, port A&B are through connected.
- \* 2 Except for some specific situations, 1000BASE-T high-traffic lines of two channels can be recorded in the capture memory simultaneously without packet loss.
- \* 3 Cannot be used to measure PoE line where the current exceeding 720mA flows continuously for 3 seconds.
- \* 4 All frames may not be recorded in the storage because of the high traffic line or low performance of the external storage.
- \* 5 For LE-8500XR only. For PC connection.
- \* 6 According to our test conditions assuming a normal usage situation.
- \* 7 Due to the open measurement method, cable maps (wire connection information) cannot be displayed.
- \* 8 It does not include uncertainty of NVP value. The NVP value must be set appropriately depending on the cable.

## 18.2 Shortcut Keys

The shortcut key operation similar to the operation by the menu number of the conventional model is available. By pressing [0] to [F] after [MENU], you can move to the frequently used setting screen.

Shortcut key	Setting display	Remark
[MENU], [0]	filter	
[MENU], [1]	Interface	
[MENU], [2]	Trigger	
[MENU], [3]	Online monitor	(*)
[MENU], [5]	Delay Time	(*)
[MENU], [6]	PoE	
[MENU], [7]	Statistic	
[MENU], [8]	Ping	
[MENU], [9]	PG	
[MENU], [A]	Except for some pages, by these operations, the functions in the touch operation guide at the bottom of the screen will be executed. (Assigned to A, B, C, D, E from the left of the guide)	(*)
[MENU], [B]		
[MENU], [C]		
[MENU], [D]		
[MENU], [E]		

 If the transition destination setting screen is not valid for the current function or operation mode, such as pressing the [MENU] or [9] key in online monitor function, the operation will be ignored.

 Please note that the shortcut key operation with (\*) is different from the operation by the menu number of the conventional model.

## 18.3 Expansion of Measurement Interface

You can expand the range of measurement target communication by using the expansion option.

### ■ Board replacement

Turn off the analyzer and disconnect all cables, then remove the standard interface sub-board and replace it with the optional sub-board.

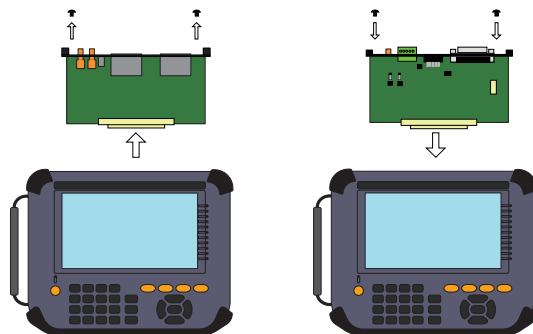

### ■ Firmware

The firmware of inserted interface sub-board starts automatically. If the firmware is not the latest one, the analyzer runs in the firmware update mode. In this case, please update the firmware to the latest one.

 18.5 Firmware Update

## 18.4 Factory reset

By the Factory reset operation, you can initialize the internal status of this analyzer and return the settings to the factory settings.

- How to

Tap “Factory reset” on the “Version” tab of “System Settings”. If you tap “OK” in the confirmation message, the main unit will automatically shut down and the settings will be initialized when you boot it next time.

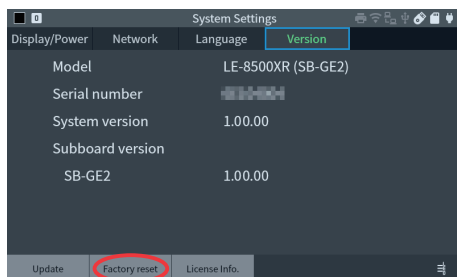

## 18.5 Firmware Update

This unit can update the firmware / recover the entire system.

The latest firmware file and system recovery file can be downloaded from LINEEYE website.

[https://www.lineeye.com/html/download\\_update.html](https://www.lineeye.com/html/download_update.html)

Download it to an easy-to-find folder on your computer, unzip it, and check the firmware file (extension: FW3) or system recovery file (extension: FWR).

The downloaded file can be written to the analyzer in the following ways.

- 1) Copy the firmware file or system recovery file to the storage device (USB memory or SDHC card).
- 2) Move from “System Settings” to “Version” and then tap “Update” to restart the device in the update mode.
- 3) After rebooting, the boot logo will be displayed and then the firmware update mode screen will appear.
- 4) Insert the storage device to which you copied the firmware file or system recovery file in the analyzer.
- 5) On the update mode screen, tap “Update”.
- 6) Select the firmware file or system recovery file.
- 7) For system recovery files, a message warning that the settings will be initialized is displayed.
- 8) It displays the message when the firmware update or system recovery is complete. Tap “OK” to restart.
- 9) To check the updated firmware version, move from “System Settings” to “Version”.

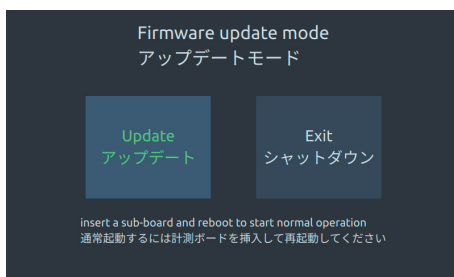

## 18.6 Trouble shooting

- This section describes how to solve problems when the analyzer does not operate normally.

Problem	Cause / Remedy
Cannot turn on the power. The power turns off immediately.	<ul style="list-style-type: none"> <li>• When operating by the battery, fully charge it.</li> <li>• If the attached AC adapter is connected but it does not improve, it may be broken.</li> <li>• If the power does not turn on, press and hold the power switch for about 1 second.</li> </ul>
Unable to charge Unable to charge enough.	<ul style="list-style-type: none"> <li>• If the power LED (red) is not lit, connect the AC adapter.</li> <li>• It cannot be charged at extremely low or high temperatures. Charge at 5 to 40°C.</li> <li>• If the battery is fully charged but the power runs out shortly, the battery may be dead.</li> </ul>
The backlight turns on but it goes out immediately.	<ul style="list-style-type: none"> <li>• Select the appropriate automatic dimming time of the backlight at the “System Settings” tab of “Display/Power” in the top menu.</li> </ul>
When it starts up, the firmware update screen appears.	<ul style="list-style-type: none"> <li>• Set the sub board securely.</li> <li>• Load the necessary firmware for the optional sub board used at the moment.</li> </ul>
When [RUN] is executed, the previous measurement data disappeared.	<ul style="list-style-type: none"> <li>• Set automatic backup at the “Auto Save” tab of “Record Control” in the top menu.</li> </ul>
The date and time of the time stamp are incorrect.	<ul style="list-style-type: none"> <li>• At the clock display on the top menu set the current date and time before measurement.</li> <li>• If the date and time often go wrong, the built-in lithium battery may have run out.</li> </ul>
Keys does not work.	<ul style="list-style-type: none"> <li>• Key operation is not possible during internal processing such as access to storage device.</li> <li>• Cannot be controlled while connected from a PC.</li> <li>• Try again by disconnecting all cables under measurement.</li> <li>• The response of the key becomes extremely slow when high-speed data (out of specification) is measured.</li> </ul>
Does not work properly. Some of the display is incorrect.	<ul style="list-style-type: none"> <li>• Turn off the power and then turn it on again.</li> <li>• Execute the factory reset (“Factoryreset” at the “Version” tab of “System Settings”). It will return to the factory default condition. Please note that all data will be erased.</li> <li>• If it still does not work, perform the system recovery.</li> </ul>
Line state LED does not light.	<ul style="list-style-type: none"> <li>• Connect the cable correctly.</li> <li>• Match the interface settings with the specification of the measurement target.</li> <li>• Check if there is any broken wire or loose connector.</li> </ul>
An SD card cannot be used on the analyzer	<ul style="list-style-type: none"> <li>• Please use optional SD card from LINEEYE.</li> <li>• Please use an SD card within the maximum SD card capacity.</li> </ul>

Problem	Cause/Remedy
The Wi-Fi function cannot be used.	<ul style="list-style-type: none"> <li>• Wi-Fi function is available only in Japan, USA, Canada and EU countries.</li> <li>• Check if the Wi-Fi SSID and KEY are set correctly.</li> <li>• Move to a location where radio waves can be easily received.</li> </ul>
Cannot connected to a computer via the USB port.	<ul style="list-style-type: none"> <li>• Check if the connection is blocked by security softwares.</li> </ul>
Unable to monitor	<ul style="list-style-type: none"> <li>• Is the cable connection and type (cross, straight) correct?</li> <li>• Is the Interface setting correct? Try turning the auto-negotiation on.</li> <li>• Does the Filter setting meet the desired conditions (disable it if not needed)</li> </ul>
Unable to use Ping	<ul style="list-style-type: none"> <li>• Adapt the configuration of Ping Opt.,Interface to the target network environment.</li> <li>• Consult with the administrator of the target network.</li> </ul>
Unable to make power off	<ul style="list-style-type: none"> <li>• Unexpected event occurs.</li> <li>• Forced shutdown by pressing and holding the power key.</li> </ul>

## 18.7 Warranty and After service

---



### Warranty

---

- When you face any problems, please contact LINEEYE distributors or LINEEYE
- Warranty

Within a period of 12 months from the date of shipment, LINEEYE warrants that your purchased products (except consumable parts such as the battery and software) are free of charge from any defects in material and workmanship, only when the products are operated in accordance with procedures described in the documents supplied by LINEEYE. If the defects exist during the Warranty period, please send back the products to LINEEYE distributors or LINEEYE. LINEEYE will repair or exchange them at no charge. In this case, the shipping charge will be at your own expense.

The foregoing warranties are the sole warranties given by LINEEYE. Above warranties shall not be applied to the products that have been modified, repaired or altered (except by LINEEYE) or that have been subjected to unusual physical or electrical stress, misuses, abuse, negligence or accidents.

LINEEYE disclaims all other warranties including the warranties of merchantability fitness for some particular purpose and noninfringement of third party right. LINEEYE cannot promise that the software is error free or will operate without any interruption.



### User Registration

---

For after service and other information, please register in our Website.



### Repair

---

For malfunction, please contact LINEEYE distributors or LINEEYE and tell us following details.

Model	LE-8500X or LE-8500XR
Serial Number	The serial number of 8-digit alphanumerical
Purchase Date	Year, Month, Day
Other	Details of malfunction



### 18.6 Trouble shooting

- Repair during warranty period  
LINEEYE repairs, following the repair instruction.  
Please provide the details of malfunction.
- Repair after warranty period  
LINEEYE will repair the products at our own expense.



## Maintenance parts

---

Maintenance parts such as lithium-ion batteries, attached cables, and AC adapters can be purchased from the store where you purchased the product or from our online shop.

- About recycling of lithium-ion batteries

Please recycle the replaced old battery in accordance with the local laws and regulations of each country.



## After Support

---

Read “FAQ” in our Website or email us.

Please refer to “FAQ” . We also have support by email regarding the technical issue. When you use it, please register your product via our website.

Website : <https://www.lineeye.co.jp/>

## LINEEYE CO., LTD.

4F., Marufuku Bldg., 39-1, Karahashi Nishihiragaki-cho, Minami-ku,  
Kyoto, 601-8468, Japan

Tel : 075(693)0161 Fax : 075(693)0163

URL <https://www.lineeye.com> Email :[info@lineeye.co.jp](mailto:info@lineeye.co.jp)

Printed in Japan